

metos

ELECTRIC BRATT PAN

OBRE 40

Installation and Operation Manual

INDEX

INSTALLATION INSTRUCTIONS ----- page --- 11

 WARNINGS ----- page --- 11

 INSTALLATION ----- page --- 11

Positioning

Assembly

In line union of the appliances

Electrical connection

Earth and unipotential connections

Important information specifically relating to appliances in the DROP-IN series

 START-UP ----- page --- 11

Function check

Nominal heat input check

 ANALYSIS OF SEVERAL FAILURES ----- page --- 11

Heating elements do not heat up

Difficult or lacking temperature adjustment

 REPLACEMENT OF PARTS SUBJECT TO CHANGE ----- page --- 11

Heating elements

Temperature regulation thermostat

USE AND MAINTENANCE ----- page --- 12

 WARNINGS ----- page --- 12

 USE ----- page --- 12

Filling of cooking container

Operation

Switching off heating

Emptying of container

 CLEANING AND MAINTENANCE ----- page --- 12

 LIST OF PARTS SUBJECT TO CHANGE ----- page --- 12

INSTALLATION INSTRUCTIONS

WARNINGS

Installation, adjustments and maintenance of the appliances must be done by authorized installers, in accordance with the safety standards in force.

The manufacturer declines any responsibility if such obligation is not observed

INSTALLATION

Positioning

- The overall/connection dimensions and the technical data are stated in the pages in the appendix.
- Install the appliances only in sufficiently aired rooms.
- Position appliances at least 10 cm from the nearby walls. Such distance can be less when the walls are incombustible or protected by a thermal insulator.
- The appliances are not suitable for built-in installation.

Assembly

- Remove the film which protects the external panels. Any glue remaining on these is to be removed with a suitable solvent.
- Assemble the spacer (if foreseen) by following the instructions enclosed with the spacer itself.

In line union of the appliances

- Put the appliances next to each other and level them at the same height.
- Unite the appliances using the special union joint-coverings supplied upon request.

Electrical connections

- Appliances are designed to operate at the voltage indicated on the rating plate.
- Each appliance must be connected to an independent mains supply of suitable capacity (total power indicated in “Technical data” table) via an input terminal board with flexible rubber cable, insulated at a level not below H07RN-F.
- Make sure that the cables length allows for the live wires to disconnect from terminal block before the yellow/green ground wire, in case of simultaneous pull.
- Automatic cutout omnipolar switches of suitable capacity (with contacts opening to at least 3 mm) and highly sensitive automatic differential protective devices must be fitted. These must ensure that there is no direct or indirect contact between live components and fault currents and the ground, in accordance with current regulations (maximum admissible leakage current 1 mA/kW).

Earth and unipotential connections

- Appliances must be earthed on terminals marked

with the symbol \perp .

- Connect the metallic structure of every electrical appliance installed to the terminals, marked by the symbol ∇ , and located next to the earth terminals (unipotential system).

Important information specifically relating to appliances in the DROP-IN series

- The appliance must be installed in strict compliance with the directions given in the attached drawings.
- Appliances should only be installed on units made of metal (and not wood and/or other flammable materials).
- Take particular care with the power lead: the channelways must be perfectly smooth with no sharp corners and/or edges. The lead must not, at any point, be subjected to temperatures of more than 50°C above normal room temperature.

START-UP

Function check electrical system

- Start-up the appliance following the instructions given; check function regularity and make sure that the controls and heating elements are in good working order, testing them with the various function positions.

Nominal heat input check

- After installation and at each maintenance intervention check the heat input of the appliance.
- The nominal heat input is stated in the “Technical data” table.
- The appliance operates at the nominal heat input when the electrical power is the one stated in Table T1.

ATTENTION If the power supply value is not within the limits indicated in Table T1, interrupt the operation of the appliance and contact the electricity delivery body.

ANALYSIS OF SEVERAL FAILURES

Heating elements do not heat up

- Check fuse valves
- Main switch off
- Insufficient power or wrong electrical connection
- Regulation thermostat faulty

Difficult or lacking temperature adjustment

- Thermostat faulty
- Wrong connection or elements faulty

REPLACEMENT OF PARTS SUBJECT TO CHANGE

IMPORTANT Before carrying out repairs, unplug appliance from mains disconnecting the main switch.

Sealed components must not be tampered with.

To reach electrical components, i.e. controls and safety devices, remove control panel and cooking container.

Heating elements

- Pull out the control knobs and remove control panel. Remove also cooking container. Disconnect the faulty heating element and replace it.

Temperature regulation thermostat

- Pull out the control knobs. Remove the front control panel. Disconnect and replace the faulty component.

USE AND MAINTENANCE

WARNINGS

Caution , appliance with hot surfaces! 
The appliance is for professional use and must be used by trained personnel. It is for the cooking of food. Any other use of the appliance is considered improper.

IMPORTANT! Don't start heating with an empty cooking container.

The installation and adaptation to other voltage must be done by qualified and authorized installers.

In case of breakdown disconnect the main switch. Sealed components must not be tampered with.

For repairs consult only authorized service centres and ask for original spare parts only.

The manufacturer declines any responsibility if such obligations are not observed.

Carefully read this booklet and keep it in a safe place. Before using the appliance carefully clean all the surfaces that will come in contact with food.

CAUTION! Don't use this unit as a fryer!

USE

Filling of cooking container

Fill-up the container following indications on Data table T1.

IMPORTANT Don't start heating with an empty cooking container!

Operation

To switch on heating of well (pilot lamp on) progressively turn the temperature regulator knob on the desired working position.

0	off
50 °C	minimum temperature
100÷250 °C	intermediate temperatures
300 °C	maximum temperature (approx.)

Switching off heating

- Turn temperature regulator knob on position **0**

(pilot lamp off).

Emptying of container

Caution , appliance with hot surfaces! 

- Switch-off heating.
- Take off container from appliance.
- To do this follow this indications:
protect hands from heat (for example using suitable gloves);
protect body from accidental hot sprinkles during lifting, transport and emptying of container.
- The container where hot foods are emptied must be large enough and of heat resistant material.

CLEANING AND MAINTENANCE

- Before any cleaning operation disconnect the electrical supply (if present).
- It is necessary to avoid rusty water being in contact with stainless steel surfaces. Therefore before filling wells with water open water tap and let water flow until it is perfectly clear.
- Clean stainless steel surfaces daily with water and non abrasive common detergents, rinse well and dry thoroughly.
- Do not use iron scouring pads or chlorate products.
- Do not use sharp objects which can scratch and ruin the steel surface.
- Do not use corrosive products to clean the floor under the appliance.
- Do not wash the appliance with water jets.
- Before a long period of inactivity disconnect the main switch. Proceed to its thorough cleaning.
- At least twice a year, ask for the intervention of an authorized technician authorized for checking the appliance. It is advisable in any case to stipulate a maintenance contract.

LIST OF PARTS SUBJECT TO REPLACEMENT

- Temperature regulator
- Knob for temperature regulator
- Heating element
- Pilot lamp

TECHNICAL DATA
T1

Model	Total power kW	V	A	H 07 RN-F	Ø MIN MAX mm	MAX capacity litres
OBRE-40	3,9	3NAC 400V	5,6	5 x 1	9+14	12,5

OBRE-40

ASENNUSKUVA - INSTALLATIONSBLD - INSTALLATION DIAGRAM

(Mitat cm - Mått cm - Measurements cm)

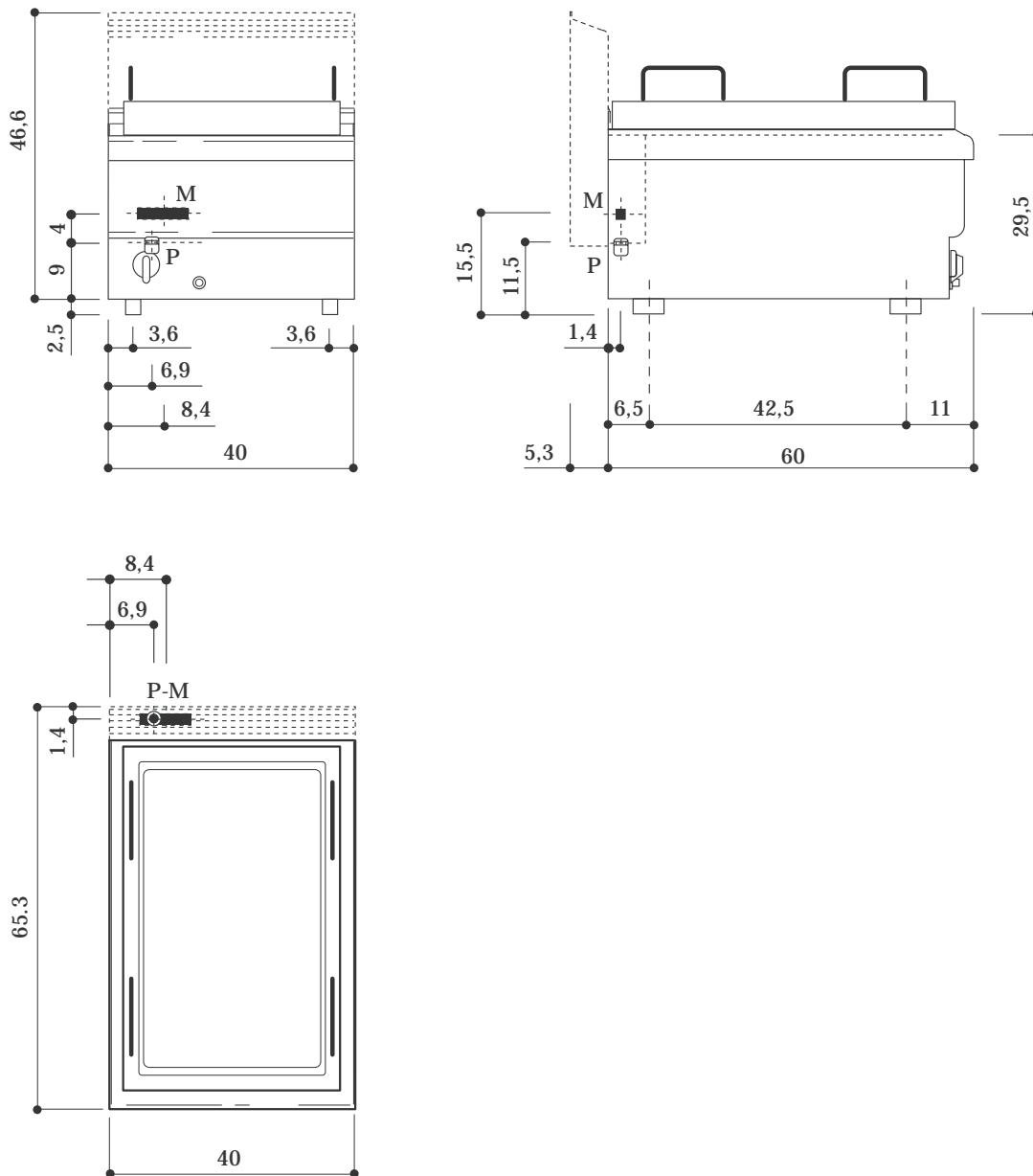

M Verkkoliitin - Nätanslutning - El. power connection blocks

P Sähkökaapelin vedonpoisto - Dragavlastare - Electric cable stress relief

OBRE-40

SE62TPS
BRE-400-D
BRE-40-D
BRE-400

DIS.N. 1049122000
DATA 19-09-1996
MOD. BRE-40

DESCRIZIONE MODIFICA	DATA	FIRMA	MOD.
AGGIUNTA MA PER MODELLI OBOP-IN	22.02.01	NARDINI	-
AGGIUNTO MODELLI SILKO	30.04.04	NARDINI	-
AGGIUNTO MODELLO OLIS	27.07.03	NARDINI	-

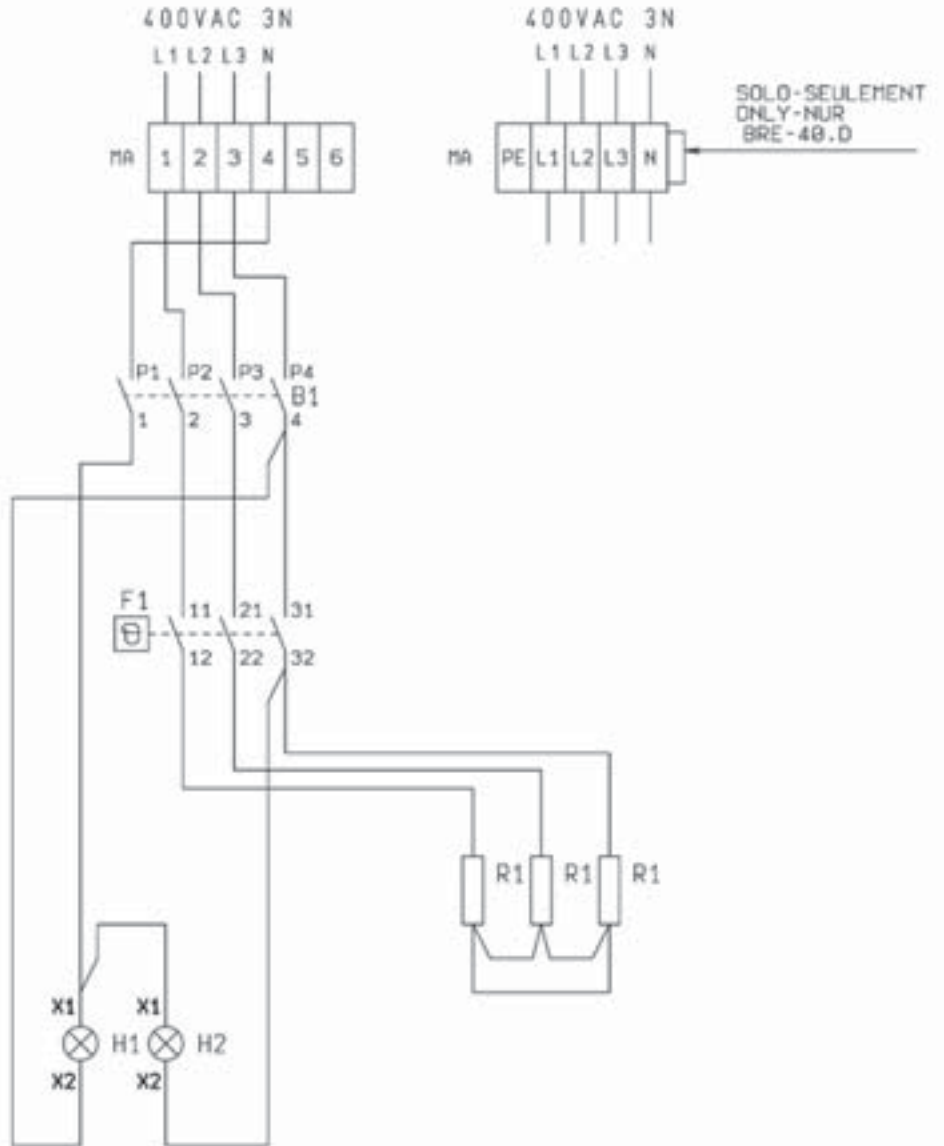

B1	INTERRUTTORE	INTERRUPTEUR	CUT-OFF SWITCH	KYTKIN
F1	TERMOSTATO DI LAVORO	THERMOSTAT	THERMOSTAT	TERMOSTAATTI
H1	SPIA VERDE	LAMPE VERT	GREEN PILOTLIGHT	VIHREÄ MERKKILAMPPU
H2	SPIA ARANCIO	LAMPE ORANGE	ORANGE PILOTLIGHT	ORANSI MERKKILAMPPU
MA	MORSETTIERA ARRIVO LINEA	BORNES ARRIVEE LIGNE	TERMINAL BLOCK	VERKKOLIITIN
R1	RESISTENZA	RESISTANCE	HEATING ELEMENT	LÄMMITYSVASTUS

POTENZA TOTALE-PUISSANCE TOTALE
HEAT INPUT-ANSCHLUSSWERT

3.9 KW 400 VAC 3N 5.6 A
XX VAC XX XX A 50-60Hz
XX VAC XX XX A