

metos

REFRIGERATED VERTICAL DISPLAY CABINET

Jolly

Installation and user manual



12.8.2014

MG4310180, MG4310182, MG4310184, MG4310186, MG4310360, MG4310362, MG4310364, MG4310366

TABLE OF CONTENTS

1.	General	3
2.	Installation	3
3.	Putting into operation.....	4
4.	Environmental conditions	4
5.	Accessories	5
6.	Advices for environment preservation	5
7.	Periodical maintenance.....	6
8.	Inconveniences and remedies	7
9.	If the appliance is temporary not in use.....	7
10.	Setting and controls.....	7
11.	Technical data	8

1. General

Please follow carefully the here under instructions to avoid end user risks, unit damages or compromise the unit performance.

The manufacturer decline all responsibilities whereas the original good performances of the unit would get worse because of any kind of modification (any adding or taking away of electrical or mechanical parts) or for not having strictly followed the instructions given in this run book. This run book has to be well kept and given to any eventual new user.

2. Installation



The installation of this appliance must be carried out in accordance with the manufacturer's instructions and following local regulations. The connection of the appliance to the electric supply must be carried out by qualified persons only.

Take out packing and clean all the cabinet following the instructions.

1. Do not install the unit in open spaces and repaired from rain. The functioning is regular with the ambient temperature and conditions indicated on the technical data plate, placed inside the tank
2. The cabinet has to be installed on a plane surface and it must be perfectly levelled: to obtain this the adjustable feet.
3. Place the cabinet away from air streams and far away from heating sources (radiators, cookers) and not directly exposed to the sun. To light the room where the cabinet is placed we do suggest to use fluorescent lamp
4. The cabinet must never lean against the wall: the back aeration grill must have an open space. Keep a distance of at least 10 cm between the wall and the cabinet. Always unplug the cabinet before moving it. You have to keep the same distance between the cabinet sides and other piece of furniture.
5. Check that the cabinet is not been damaged during the transport.
6. Do not leave objects on the equipment, such as containers, plants, etc. and leave at least 50 cm of free space above the equipment.
7. The use of this equipment by children or people with physical, sensorial, mental or motion disability, or people who do not have the necessary knowledge and experience, could lead to dangerous situations. The people responsible for their safety should give them explicit instructions or check the use of this equipment;
8. Make sure that children do not play with the equipment.

ATTENTION!



DO NOT WET THE CABINET PARTS WHERE ELECTRIC COMPONENTS ARE PRESENT. DO NOT FORCE ANY PART OF THE CABINET WHERE THERE IS THE REFRIGERATING CIRCUIT. THE CABINET IS NOT SUITABLE FOR WORKING IN DANGEROUS PLACES WITH RISK OF FIRE, EXPLOSIONS AND/OR RADIATION.



Check that the actual network voltage corresponds to the one stated on the technical data plate . Do not lay anything on the cabinet (plants, boxes, etc..) and leave a free space of minimum 50 cm. over the cabinet.

The electric line where the unit will be connected must be protected by any high sensitivity differential switch (In=16A, Id=30mA) and connected to general earthing.



THE EARTHING OF THE INSTALLATION IS A SAFETY STANDARD WHICH IS ENFORCED BY LAW. OUR COMPANY HAS PROVIDED FOR THIS CONNECTION ACCORDING TO THE EXISTING STANDARDS AND THEREFORE WE DECLINE ANY RESPONSIBILITY FOR POSSIBLE DAMAGES TO PEOPLE OR THINGS.



Do not place the feeding cable in contact with asperities, smudging or edges or with high temperature parts. Please arrange the feeding cable to NOT retract in the motor cage grill, it could be damaged. For plugging do not absolutely use any reduction or multiple current-tap.

MODEL 250 - INSTALLATION FOR SINGLE-PHASED POWER SUPPLY



ONLY SPECIALISED TECHNICIANS SHALL CARRY OUT THIS OPERATION

The wall is equipped with power supply cable 5 x 2.5 sq. mm., indicated for three-phased power supply with neutral. Follow these operations to connect the device to the single-phased 230 V network.

- Connect the 3 phases (black, brown, gray cables) together, by connecting them directly to a bi-polar differential-magnetothermal switch $I_n = 20\text{ A}$, $I_d = 30\text{ mA}$.
- Connect the pale blue cable (neutral) to the other terminal of the switch.
- Connect the yellow-green cable (earth) to the earth terminal.

3. Putting into operation



Before put the plug in the socket let it stay still for about an hour. If the cabinet has been transported in horizontal position, please wait 24 hours.



AFTER PLUGGING MAKE RUN THE CABINET FOR ABOUT 1 HOURS WITH THE LIGHT OFF AND EMPTY. THEN LOAD THE PRODUCTS: DO NOT PLACE THE PRODUCTS OVER THE SHELVES EDGES, BECAUSE OVER THE FRONTAL EDGE THE TEMPERATURE IS NOT ENOUGH FOR GOD PRESERVATION, AND THE PRODUCT COULD OBSTRUCT THE GOOD CIRCULATION OF THE REFRIGERATED AIR.



DO NOT OBSTRUCT THE AIR INPUT POINT AND THE AIR SUCKING GRILL PLACING ANY PRODUCTS OR WRAPPINGS AGAINST THEM PLACE THE PRODUCTS LEAVING SOME SPACE BETWEEN ONE ANOTHER (1 CM) TO ALLOW AIR CIRCULATION.



DO NOT OVER PLACE THE PRODUCTS FOR MORE THAN 2/3 OF THE HEIGHT SPACE AVAILABLE . AVOID TO PLACE TOO LITTLE QUANTITY OF GOODS ON THE SHELVES BECAUSE THIS WOULD COMPROMISE THE CABINET PERFORMANCE

The standard cabinet are designed to function at climate class 3.

The minimum external temperature limit is 16° C: The maximum humidity level is 65% UR
Illumination: 100 lx.

The temperature checking and the defrosting are made by an electronic thermostat: we do advise to keep the set value as it is set before coming out of the factory. An inferior value, specially in warm and dump places can block the ice evaporator and stop the cabinet functioning. If you have to do a complete defrosting before doing it place all the products into another refrigerator.

Defrosting is automatic and it is started by the electronic checking system which is set before coming out of the factory. While defrosting the compressor stop working while the refrigerating fans keep on working.

Do not introduce into the cabinet products that have temperature higher to that set of the cabinet. The cabinet is suitable only to preserve and not to cooldown temperature. DO NOT PLACE THE PRODUCTS BEFORE THE CABINET HAS REACHED THE RUNNING TEMPERATURE

Please check before putting the goods into the cabinet, that the use of the cabinet which is declared from the manufactured is compliant with the goods themselves. It is forbidden to use the cabinet to store pharmaceutical products.

The maximum loading possible is 50Kg/meteres for each shelf (example: if the shelf is 1,8 MT the maximum load is 90 Kg)

4. Environmental conditions

Since the excess of humidity does not allow the cabinet to work properly, to keep the environmental conditions like what stated by the technical data, in the room where the cabinet is installed it could be necessary to install an air conditioner that allows to control the relative humidity .

Place the cabinet away from air stream.

The cabinet must be placed away from doors and/or forced air sources (in/out-let of fans/air-conditioner or radiators) and also in places repaired from air drafts.

5. Accessories

Use only the accessories given with the cabinet. Any self-made accessories can hinder the correct air circulation and therefore will not allow the cabinet to work properly.

Attention: the evacuation of condensation water is granted for environmental climatic condition which have a percentage of 65% max.

ENERGY SAVING SLIDING DOORS (option)

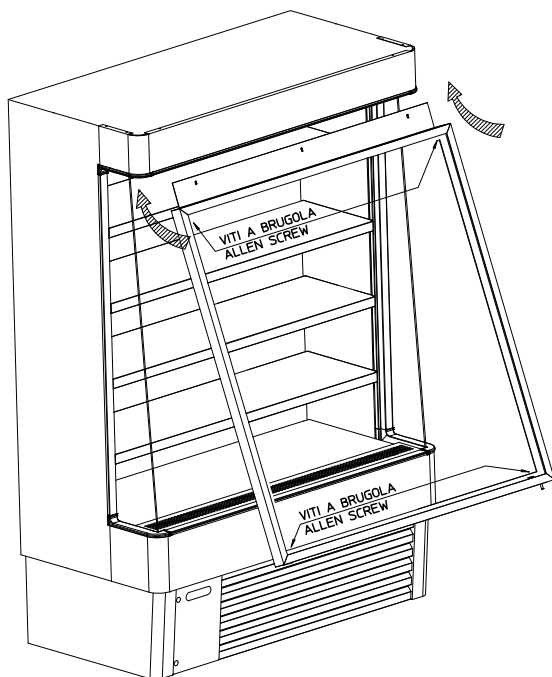

INCASTRARE IL TELAIO NEL MOBILE COME INDICATO IN FIGURA.
FISSARE MEDIANTE LE QUATTRO VITI A BRUGOLA POSTE NEGLI ANGOLI.
COMPLETARE IL FISSAGGIO CON TRE VITI AUTOFILETTANTI ALL'INTERNO
DEL MOBILE LATO SUPERIORE.
INSERIRE LE VETRATE NEL TELAIO CONTROLLANDO CHE I RULLINI
SCORRINO PERFETTAMENTE SULLE GUIDE.

FIT THE FRAME IN THE CABINET AS SHOWN.
SET USING THE FOUR ALLEN SCREWS IN THE CORNERS.
THE FASTENER WITH THREE SCREWS INSIDE THE CABINET TOP.
INSERT THE GLASS INTO THE FRAME MAKING SURE THAT THEY SLIDE
SMOOTHLY ONTO THE ROLLER GUIDES.

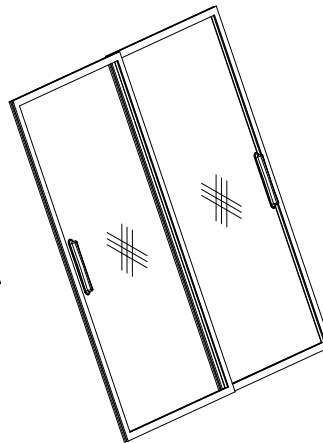

ASCIUGARE I VETRI LATERALI CON PANNINO QUALORA
SI RENDA NECESSARIO TALE OPERAZIONE.

TO DRY SIDE GLASS WITH A CLOTH IF YOU
NEED TO DO SO

6. Advices for environment preservation



Packing

The packing is 100% recyclable and the recycling logo is printed on it.

To waste it follows what enacted by local laws.

The plastic bags and polystyrene parts must be taken away from children as they could be dangerous.



The crossed-out wheeled bin means that within the European Union the product must be taken to separate collection at the product end-of life. This applies to your device but also to any enhancements marked with this symbol. Do not dispose of these products as unsorted municipal waste.

7. Periodical maintenance



For any adjustments on the refrigeration you must remove the electric plug.



The mechanic parts of the cabinet do not need any periodical maintenance, still for a good preservation of the cabinet an accurate periodical cleaning is necessary:

- **external body:** when necessary, the external body should be cleaned with a dry cloth. To remove stains use warm water and neutral soap then rinse well and dry .
- **stainless still surfaces:** wash with warm water and neutral soap, rinse well and dry with a soft cloth. Avoid the use of alcohol, methylated spirits or other solvents.
- **Surfaces in plastic materials:** wash with water and neutral soap. Rinse well and dry with a soft cloth. Avoid the use of alcohol, methylated spirits or other solvents.
- **Glass surfaces:** only use product specific for glass cleaning. Avoid to use water that could leave a film of calcium on the glass surfaces.

For the tank cleaning proceed as follows:

1. **Switch off the unit and remove the plug from the socket**
2. **Remove the products and the shelves from the cabinet**
3. **Wait that the cabinet temperature is equal to the ambient one**
4. **Wash the inside of the cabinet with water and neutral soap then dry it with a cloth**
5. **Do not use jet of water to clean the cabinet: electrical wiring can be damaged**

Replace the shelves and switch on the cabinet with the light off: after 1 hour the unit is ready and you can put the products in.



DRAINING POINT CLEANING

Attention: The following operation has to be done only by the customer care service or skilled technical personnel. Draining points, drain trap and eventual water trap have to be checked every two months. Unplug the cabinet before moving it and start maintenance operations.



CONDENSER CLEANING (low front position)

Attention: the operation hereunder described must be done by an skilled technical personell. Every month clean the condenser from impurity and dust that lay on the wiring and don't allow a proper air circulation. A dirty condenser impairs the unit performances and make it waste electric energy. To clean the condenser use bristle brushes or better a vacuum- cleaner. If necessary remove the protection grill. Unplug the cabinet before moving it or making any kind of maintenance

ALL NOT ORDINARY MAINTENANCE OPERATIONS MUST BE DONE BY SKILLED TECHNICAL PERSONNEL

We advise you to schedule a periodic checking with the customer care service to grant the good performance and safety of the cabinet.

8. Inconveniences and remedies

Most of the functioning inconveniences are generally due to mere reasons or to defective electrical connections. These can be easily be solved:

The unit does not start:

- Check if there is power at the wall socket;
- Check that the unit is properly plugged.

The internal temperature is not cold enough:

- Check if there is some products or something else that doesn't allow the air circulation .
- Check that the cabinet is not placed too close to any heating source;
- Check that the cabinet leans against the wall and that the front grill is free from any obstructions;
- Check the thermostat position;
- Check that the condenser is not blocked by dirt; to clean it use a bristle brush or a vacuum- cleaner.

The unit is noisy:

- Check that all bolts and nuts are properly fasten
- Check if any pipe or blade touches any other parts of the cabinet
- Check that the cabinet is placed on a plane surface

If the inconveniences will not stop please contact the nearest assistance-service centre.



IN CASE THE SUPPLY CABLE IS DAMAGED, THE MANUFACTURER OR THE AFTER-SALES SERVICE, OR QUALIFIED TECHNICIAN SHALL REPLACE IT, IN ORDER TO PREVENT ANY POSSIBLE RISK.



THE LAMP REPAIR AND REPLACEMENT SHALL BE CARRIED OUT BY QUALIFIED TECHNICIANS, WITH POWER SUPPLY DISCONNECTED. REPLACE WITH IDENTICAL LAMPS.



ONLY QUALIFIED TECHNICIANS SHALL CARRY OUT THE EXTRAORDINARY MAINTENANCE INTERVENTIONS.

9. If the appliance is temporary not in use

When the cabinet will not be used for a long time, please proceed as follows:

- Take the plug off the socket ;
- Defrost clean and dry the inside and outside of the cabinet
- Cover the cabinet with a curtain, place it in a dry room and repaired from atmospheric agents

When the cabinet will be started up again:

- Repeat the voltage checking given for first installation;
- Wait for one hours at least before putting the products inside.

10. Setting and controls

The equipment is equipped with switcher and temperature control.

• Lights switcher:

Switching it on you light the lamp (for the model with the canopy it also light it in the same time).

• Electronic thermostat:

See the thermostat user book to know all setting details.

11. Technical data

Temperature	0°C +2°C
Voltage and Frequency	230 V~ 50 Hz
Gas	R507
Net dimension	685 x 737 x 1985 mm (l x p x h)
Packed dimension	750 x 760 x 2120 mm (l x p x h)
Gross capacity	438 l
Net capacity	318 l
Gross weight	142.00 Kg
Net weight	126.00 Kg
Heat insulation	In polyurethane injected "HCFC/CFC" free
External cabinet	Stainless steel sheet scotchbrite - AISI 430
Cabinet back	Galvanized sheet
Inner tank	Stainless steel sheet - AISI 304
Frontal grid - colour	Stainless steel sheet scotchbrite - AISI 430
Compressor	1 HP
absorbed power	1240 W
Absorbed current	7 A
Condensator	Packed system (finned) with powered fan
Evaporator	Packed system (finned) with powered fan
Defrosting	Automatic defrosting with automatic water evaporation
Climatic class - EN 441	3 (25°C-60%UR)
Plug	European - Angular Plug
Thermometer/Thermostat	Electronic
Inner levels	4 reclining shelves + 1 at the bottom
Standard equipment	4 tier adjustable shelving - 40 mm ticket strip on shelves - Adjustable feet - Night curtain
Optional	Transparent risers (40 mm) for shelves - wheels
Packaging	Polystyrene + wood + film pack

The manufacturer will reserve the right to make any modification without prior notice.

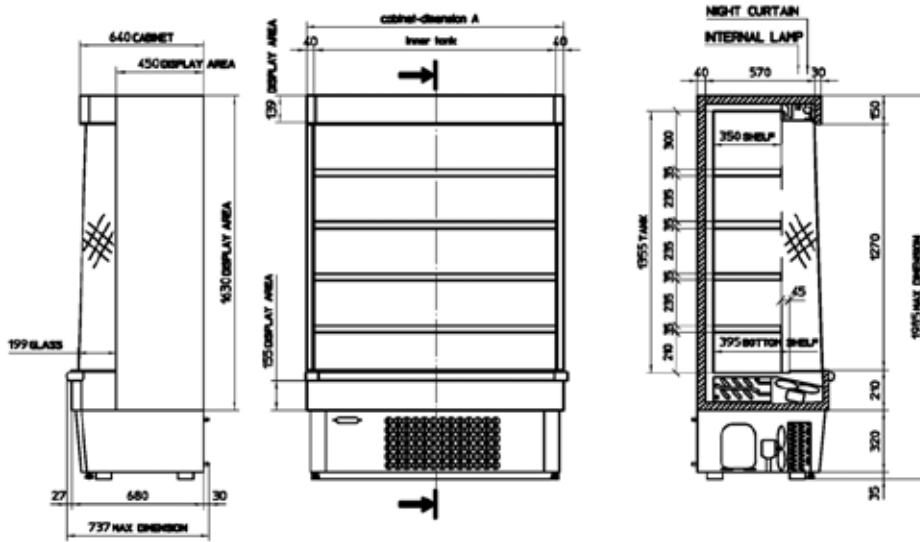

FRONTAL DISPLAY AREA LxH DIMENSION (SHRIMPABLE LxH)	
MULTIDECK7	1020x139
MULTIDECK10	1320x139
MULTIDECK14	1670x139
MULTIDECK19	2220x139

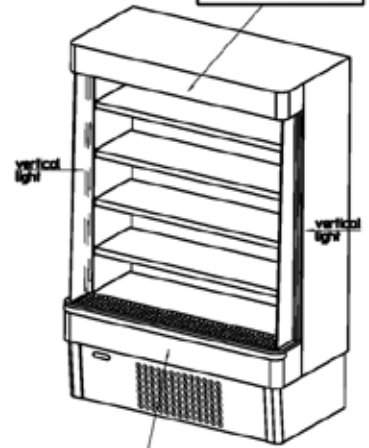

FRONTAL DISPLAY AREA LxH DIMENSION (SHRIMPABLE LxH)	
MULTIDECK7	1100x155
MULTIDECK10	1400x155
MULTIDECK14	1750x155
MULTIDECK19	2300x155

MODEL	cabinet-dimension A	Inner tank	TOTAL DISPLAY AREA (sq2)	NET CAPACITY	GROSS CAPACITY	PACKAGE DIMENSIONS W x D x H	20 FT	40 FT	CANON	MAX
MULTIDECK 7	685	600	0.76	318	438	750 x 760 x 2120	21	48	54	54
MULTIDECK 10	985	900	1.14	477	657	1050 x 760 x 2120	15	33	38	36
MULTIDECK 14	1335	1250	1.58	663	913	1400 x 760 x 2120	12	25	28	28
MULTIDECK 19	1885	1800	2.28	954	1314	1950 x 760 x 2120	9	18	20	21

MODEL	CAPACITY CANES 330 ML	CAPACITY BOTTLE 500 ML ACQUA	CAPACITY BOTTLE 500 ML BIRRA	CAPACITY BOTTLE 530 ML BIRRA	CAPACITY CANES 300 ML BIRRA
MULTIDECK 7	414	234	160	210	234
MULTIDECK 10	598	338	240	315	338
MULTIDECK 14	828	494	340	420	468
MULTIDECK 19	1242	702	500	630	702

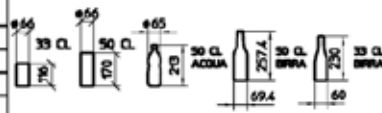

JOLLY

S_41075 - 03



DICHIARAZIONE DI CONFORMITA'
CONFORMITY DECLARATION
DECLARATION DE CONFORMITE'
ÜBEREINSTIMMUNGSERKLÄRUNG
DECLARACION DE CONFORMIDAD

Il prodotto:
the product:
 le produit:
die produkte
 el producto:

Contrassegnato sulla targa matricolare:
Marked on the serial plate:
 Qui sont marquès sur la plaquette technique:
Die auf dem Geräteschild gekennzeichnet sind:
 Que està escrito la tarjeta tecnica:

è conforme alle seguenti direttive:
is in conformity with the following directives:
 est conforme aux suivantes directives:
übereinstimmt mit den folgenden Grundsätzen:
 cumple las siguientes directivas:

2006/42/CE
2006/95/CE
2004/108/CE
97/23/CE

e succ. mod. ed integrazioni.
And following modifications.
 et suivantes modifications.
und folgende Anderengen.
 y sucesivos modificatiõnes.

E' inoltre conforme alle seguenti norme tecniche armonizzate:
Is moreover in conformity with following technical harmonized standards:
 Il est en outre conforme aux suivantes normes techniques harmonisèes:
Außerdem gemäß den folgenden technischen und abgestimmten Grundsätzen ist:
 Està ademas conforme a las siguientes normas tecnicas:

UNI EN 292-1	Edit. 1991
UNI EN 292-2	Edit. 1991
CEI EN 50106	Edit. 1997
CEI EN 55014-1	Edit. 1998
CEI EN 55014-2	Edit. 1998
CEI EN 50081-1	Edit. 1993
CEI EN 61000-3-2	Edit. 1993
CEI EN 61000-3-3	Edit. 1994
CEI EN 60335-1	Edit. 2004
CEI EN 60335-2-89	Edit. 2004
EN 50366	Edit. 2003

metos
kitchen intelligence®