

metos

VACUUM PACKAGING MACHINES

COMPACT ECO

TYPE: Mini, Maxi, Gastrovac, Pro, Super

Installation and Operation Manual



S/N:

Rev.: 2.0

Dear Customer,

Congratulations on deciding to choose a Metos appliance for your kitchen activities. You made an excellent choice. We will do our best to make you a satisfied Metos customer like thousands of customers we have around the world.

Please read this manual carefully. You will learn correct, safe and efficient working methods in order to get the best possible benefit from the appliance. The instructions and hints in this manual will give you a quick and easy start, and you will soon note how nice it is to use the Metos equipment.

All rights are reserved for technical changes.

You will find the main technical data on the rating plate fixed to the equipment. When you need service or technical help, please let us know the serial number shown on the rating plate. This will make it easier to provide you with correct service.

For your convenience, space is provided below for you to record your local Metos service contact information.

METOS TEAM

Metos service phone number:.....

Contact person:.....

1. General	1
1.1 Symbols used in the manual	1
1.2 Symbols used on the appliance	1
1.3 Checking the relationship of the appliance and the manual	1
2. Safety	2
2.1 Safe use of the appliance	2
2.2 Disposal of the appliance	2
2.3 Safety precautions	2
3. Functional description	3
3.1 General	3
3.2 Operating panel	3
4. Operation instructions	4
4.1 Warm up position	4
4.2 Vacuuming and sealing	4
4.2.1 Vacuuming	4
4.2.2 Sealing	4
4.3 After use	5
4.3.1 Daily cleaning	5
4.3.2 Seal bar maintenance	5
4.3.3 Weekly maintenance	6
4.3.4 Monthly maintenance	6
4.3.5 Annual maintenance	6
4.3.6 Oil	6
5. Installation	7
5.1 Positioning the appliance	7
5.2 Electrical connections	7
5.3 Oil and temperature	7
6. Troubleshooting	8
8. Technical specifications	51

1. General

Carefully read the instructions in this manual as they contain important information regarding proper, efficient and safe installation, use and maintenance of the appliance.

Keep this manual in a safe place for eventual use by other operators of the appliance.

The installation of this appliance must be carried out in accordance with the manufacturer's instructions and following local regulations. The connection of the appliance to the electric and water supply must be carried out by qualified persons only.

Persons using this appliance should be specifically trained in its operation.

Switch off the appliance in the case of failure or malfunction. The periodical function checks requested in the manual must be carried out according to the instructions. Have the appliance serviced by a technically qualified person authorized by the manufacturer and using original spare parts.

Not complying with the above may put the safety of the appliance in danger.

1.1 Symbols used in the manual



This symbol informs about a situation where a safety risk might be at hand. Given instructions are mandatory in order to prevent injury.



This symbol informs about the right way to perform in order to prevent bad results, appliance damage or hazardous situations.



This symbol informs about recommendations and hints that help to get the best performance out of the appliance.

1.2 Symbols used on the appliance



This symbol on a part informs about electrical terminals behind the part. The removal of the part must be carried out by qualified persons only.

1.3 Checking the relationship of the appliance and the manual

The rating plate of the appliance indicates the serial number of the appliance. If the manuals are missing, it is possible to order new ones from the manufacturer or the local representative. When ordering new manuals it is essential to quote the serial number shown on the rating plate.

2. Safety

2.1 Safe use of the appliance

To avoid risk of electric shock or damage to the machine, always switch off the machines and isolate from the power supply before carrying out any maintenance or cleaning.

2.2 Disposal of the appliance

When you dispose of your machine, it can still contain valuable substances and materials. Do not dispose of the machine as industrial waste, but enquire at your local government authority about the possibilities for recycling or environmentally-friendly disposal of the material.

Most parts of the machine have been manufactured from stainless steel and can be disposed of as scrap metal in the normal way.

The printed circuit boards and the components mounted on them are electronic waste. Deliver old printed circuit boards to specialised companies for environmentally-friendly processing.

2.3 Safety precautions

Always unplug the machine when carrying out maintenance or repairs.



Never use high-pressure water to clean the machine as this can cause irreparable damage to the machine and to the electronics.



Never use the machine without the seal bar installed.

To prevent accidents always replace damaged or oxidized gas or torsion springs in the lid.

Before vacuum packing any sauces, soups or other liquids refer to the relevant section in the Operating chapter for correct and safe setting up of the machine.

An authorized service representative must carry out all repairs.

3. Functional description

3.1 General

Metos Compact Eco models - Mini, Maxi, Gastrovac and Super - are machines that function automatically. When the filled vacuum pouch has been put in the vacuum chamber and the lid is closed the operation will start automatically. The machine will automatically follow the entered program from vacuuming to sealing. After the sealing has been completed the vacuum pump will turn off and the lid will automatically open.

3.2 Operating panel

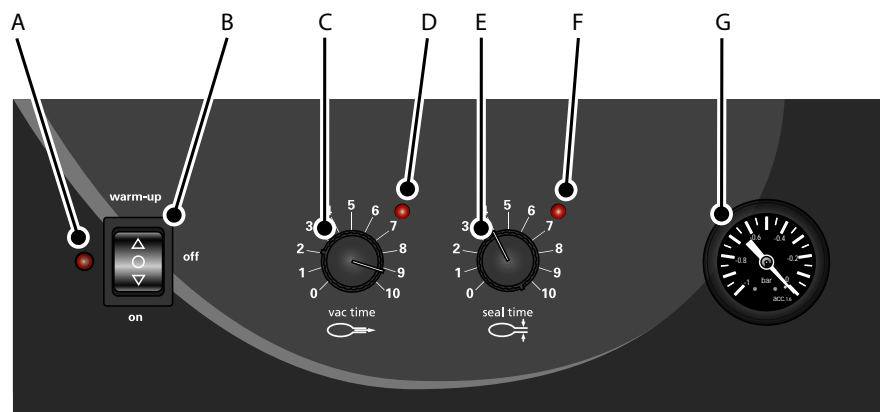

- A. On/Off indicator
- B. On/Off switch
- C. Vacuum dial
- D. Vacuum indicator
- E. Seal dial
- F. Seal indicator
- G. Vacuum gauge

4. Operation instructions

4.1 Warm up position

After the machine has been switched off for a period of time we recommend that the machine is “warmed up”. Set the On/Off switch in the position WARM UP (B). Allow the pump to run (10 minutes max.). The main switch can then be reset to ON. The machine is ready to be used.

4.2 Vacuuming and sealing

Set the On/Off Switch (B) to position ON. The red light will light up, (adjacent to the switch) to indicate that the machine is ready to be used. The vacuum chamber contains filler plates. When the vacuum pouches are filled, a number of the filler plates must be removed (or not for smaller packs) so that the vacuum pouch lies directly on the sealing bar, ensure that the pouch lies half above the bar and half below it. The vacuum pouches should never stick out of the machine to stop the lid closing.



Never try to force the lid closed.

4.2.1 Vacuuming

Depending on the desired vacuum, the vacuum dial (C) on the control panel can be set. A red light (D) serves as a control indicator of the vacuum time. Start with position 3. If there is insufficient vacuum, set the dial to a higher value. The attained vacuum can be seen on the vacuum gauge (G) on the right side of the control panel. It is important that the vacuum time for products with enclosed air is extended.



Don't just start vacuuming sauces or other liquid products. When vacuuming sauces or soups, the pressure in the vacuum chamber must be carefully monitored, because the boiling point of liquids is lower as the vacuum percentage goes up. As soon as the boiling point has been reached, you can see the gas bubbles in the product.

4.2.2 Sealing

The seal time is set by the seal dial (E), The red light (F) serves as a control indicator of the sealing time. Starting with position 3, if the sealing time is too long (scorching the bag), set the dial to a lower value; if the sealing time is too short (the sealed product easily opens), set the dial to a higher value.

4.3 After use

4.3.1 Daily cleaning

Regular and thorough maintenance prevents breakdowns, prolongs the machine's operational life and guarantees optimum hygiene.

- Clean the lid, insert plates, bottom and walls of the vacuum chamber with a damp clothe.
- Pay particular attention to the silicon strip in the lid.
- Clean the control panel with a dry cloth.
- In order to prevent oxidation in the pump, the vacuum pump must run for about 5 minutes after cleaning, (see "Warm up" procedure) to allow the condensed water in the oil can evaporate.
- Do not clean the transparent lid with synthetic cleaning agent as this weakens the acrylic material.

4.3.2 Seal bar maintenance

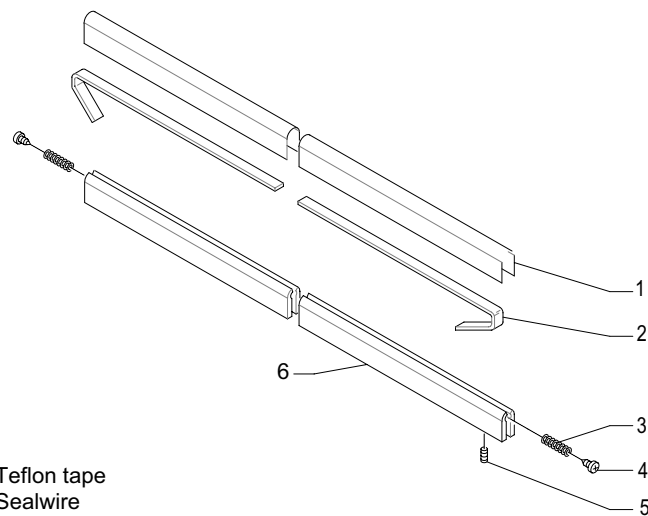

1. Teflon tape
2. Sealwire
3. Spring
4. Screw
5. Hexagon nut
6. Beam

- Clean the sealing and counter bars daily to ensure optimum sealing of the packaging material. Use a dry cloth for this purpose.
- Check the condition of the sealing wires regularly. They should be free of kinks and should be tightly strung on the sealing bar. For flawless operation the Teflon tape must be free of damage.
- If the sealing wires or the Teflon tape are damaged, replace them immediately.
- Check the counter bar. This is made of silicone, which generally has a long operational life and therefore does not need replacing often. However, if parts of the beam are scorched, replace the silicone strip immediately.
- Ensure that spare sealing wires and Teflon tape are always kept in stock.

4.3.3 Weekly maintenance

- Check the oil, add oil if necessary.
- Check the condition.
- Check the silicone gasket in the lid; replace if damaged.
- Check the silicone strip in the counter bar; replace if damaged.

4.3.4 Monthly maintenance

- Check the condition of the oil. Note: Replace the oil after 160 hours of operation.
- If the machine is not used frequently, change the oil every 6 months.

4.3.5 Annual maintenance

- Check the condition of the vacuum hoses and pipes and replace them if necessary.
- Check the condition of the silicone strip of the counter bar and replace if necessary.
- Check the condition of the gas springs in the lid and replace them if necessary.

4.3.6 Oil

The oil in the vacuum pump must be checked and replaced on a regular basis.

5. Installation

5.1 Positioning the appliance

Make sure the machine is level and has been placed on a solid level surface.



To ensure easy access for maintenance and sufficient ventilation, the machine must not be closed in and is easily accessed from all sides.

The main cable must be routed in such a manner to minimize any tripping hazard or that will cause damage to it.

5.2 Electrical connections

Before connecting the machine to the mains make sure that the voltage stated on the specifications plate is the same as that of the mains supply and that the connection is properly earthen.

The standard machine must be connected to 230 Volt - 1 phase - 50 Hertz (depending on the country).

5.3 Oil and temperature

Check the oil level. It is crucial that there is enough oil in the machine.

The temperature in the work space should not be lower than 10°C, as the oil in the vacuum pump will thicken and prevent the smooth operation of the pump.

6. Troubleshooting

If the machine indicates a problem, use the following table to check whether you can solve the problem.



Do not carry out service, maintenance or repair work on the machine when it is indicated that the authorized service should carry this out.

Always have the authorized service carry out the repair and maintenance work.



Always switch off the machine at the main switch and/or remove the plug from the socket during maintenance work. Lock the main switch with a padlock.

Problem	Possible cause	Measures
Machine does not work.	The plug is not in the socket.	Put the plug in the socket.
	A fuse in the machine is broken.	Consult your service.
	The ON/OFF switch is in the OFF position.	Put the switch in the ON position.
The vacuum pump does not function correctly.	The oil is too thick, the temperature is too low.	Let the pump warm up.
There is insufficient vacuum.	The value entered for the vacuum function is too low.	Increase the vacuum level.
	There is not enough oil in the pump.	Replenish the oil.
	The oil is dirty.	Change the oil.
	The suction filter is blocked.	Contact your service.
	The pump's spray filter is blocked.	Contact your service.
The machine does not work, but the lights are on.	The lid's silicon gasket is damaged.	Replace the silicon gasket.
	The lid microswitch is damaged.	Contact your service.
	The thermal safeguard has switched the machine off due to overheating.	Check if the ventilation openings are free from obstructions. Let the machine cool down and switch again. If the fault persists, contact your service.
	A fuse could have ruptured.	Contact your service.
Insufficient vacuum in the bag.	There is an internal malfunction.	Contact your service.
	The vacuum pouch is of inferior quality.	Select vacuum pouches of a better quality.
	The product has damaged the pouch.	Use a new pouch.
	There is insufficient room between the sealing bar and the counter bar.	Check the position of the sealing bar.

Troubleshooting

The vacuum pouch is incorrectly sealed.	The vacuum pouch is incorrectly placed on the sealing bar.	Place the opening of the vacuum pouch over the sealing bar correctly.
	The sealing time is not set correctly.	Adjust the sealing time value.
	There is a break in the sealing wire.	Replace the sealing wire.
	The sealing bars are dirty.	Clean the sealing bars.
	The teflon tape is worn.	Replace the teflon strip.
	The counter bar is damaged.	Replace the silicon strip.
	The vacuum pouches are of inferior quality.	Select better quality vacuum pouches.
	The opening of the vacuum pouch is contaminated	Remove any obstructions from the opening of the pouch. Make sure the opening of the package remains clean while filling or replace the bag.

8. Technical specifications

Technical specifications

Item	Type	Specification
Size of the machine WxDxH	Mini	330x460x389 mm
Size of the machine WxDxH	Maxi	330x460x380 mm
Size of the machine WxDxH	Gastrovac	415x520x415 mm
Size of the machine WxDxH	Pro	550x580x470 mm
Size of the machine WxDxH	Super	535x655x990 mm
Weight of the machine	Mini	31 kg
Weight of the machine	Maxi	41 kg
Weight of the machine	Gastrovac	55 kg
Weight of the machine	Pro	68 kg
Weight of the machine	Super	
Size of the packed machine WxDxH	Mini	540x630x500 mm
Size of the packed machine WxDxH	Maxi	540x630x580 mm
Size of the packed machine WxDxH	Gastrovac	540x630x700 mm
Size of the packed machine WxDxH	Pro	650x630x700 mm
Size of the packed machine WxDxH	Super	
Weight of the packed machine	Mini	36 kg
Weight of the packed machine	Maxi	46 kg
Weight of the packed machine	Gastrovac	65 kg
Weight of the packed machine	Pro	83 kg
Weight of the packed machine	Super	
Size of the vacuum chamber WxDxH	Mini	280x130x365 mm
Size of the vacuum chamber WxDxH	Maxi	280x130x365 mm
Size of the vacuum chamber WxDxH	Gastrovac	320x135x340 mm
Size of the vacuum chamber WxDxH	Pro	420x170x370 mm
Size of the vacuum chamber WxDxH	Super	455x110x530 mm
Sealing configuration:		
1xsealing beam:L mm	Mini	270 mm
1xsealing beam:L mm	Maxi	270 mm
1xsealing beam:L mm	Gastrovac	320 mm
1xsealing beam:L mm	Pro	420 mm
1xsealing beam:L mm	Super	420 mm
Vacuum pump:		
capacity 50Hz m3/h	Mini	3
capacity 50Hz m3/h	Maxi	8
capacity 50Hz m3/h	Gastrovac	16
capacity 50Hz m3/h	Pro	16
capacity 50Hz m3/h	Super	21
capacity 60Hz m3/h	Mini	3,6
capacity 60Hz m3/h	Maxi	9.6
capacity 60Hz m3/h	Gastrovac	19
capacity 60Hz m3/h	Pro	19
capacity 60Hz m3/h	Super	24
Final pressure mbar	Mini	15
Final pressure mbar	Maxi	2
Final pressure mbar	Gastrovac	2

Technical specifications

Item	Type	Specification
Final pressure mbar	Pro	2
Final pressure mbar	Super	2
Oil quantity Ltr	Mini	0,06
Oil quantity Ltr	Maxi	0,25
Oil quantity Ltr	Gastrovac	0,3
Oil quantity Ltr	Pro	0,3
Oil quantity Ltr	Super	0,5
Weight vacuum pump kg	Mini	5,1
Weight vacuum pump kg	Maxi	10,3
Weight vacuum pump kg	Gastrovac	18
Weight vacuum pump kg	Pro	18
Weight vacuum pump kg	Super	19
Noise 50 Hz dB (A)	Mini	59
Noise 50 Hz dB (A)	Maxi	59
Noise 50 Hz dB (A)	Gastrovac	60
Noise 50 Hz dB (A)	Pro	60
Noise 50 Hz dB (A)	Super	62
Noise 60 Hz dB (A)	Mini	59
Noise 60 Hz dB (A)	Maxi	59
Noise 60 Hz dB (A)	Gastrovac	64
Noise 60 Hz dB (A)	Pro	64
Noise 60 Hz dB (A)	Super	62
Oil recommendation at a temperature of 5-12°C		VM 068
Oil recommendation at a temperature of 12-30°C		VM100
Oil recommendation at a temperature of 30-40°C		VS 100 or VC 101
Electrical connection:		
Maximum permissible voltage variance		(-)10% to (+)10%
Maximum leakage		0.1mbar/s
Ambient conditions:		
Temperature		+ 5 to + 30° C
Transportation temperature		- 25 to + 55°C
Humidity		30% to 95% (without condensation)
Positioning		Inside, level, free of walls

COMPACT ECO

CE DECLARATION OF CONFORMANCE

(according to annex II A of the machine guideline)

We, HFE Vacuum Systems B.V.
Het Sterrenbeeld 36, 's-Hertogenbosch,
The Netherlands,

declare totally on our own responsibility that the products:

Vacuum packing machines:

Henkovac , METOS 521, METOS 621, METOS 721, METOS 940 and METOS 563

to which this declaration refers, comply with the following standards:

- **EN 60204-1: 1997;**
- **EN 60335-1: 1994;**
- **EN 55014, EN 60555-2 and EN 60555-3**
- **EN 5514-2 carried out using the values of the EN 50082-2**

according to the determinations of:

- **the machine guideline 89/392/EEG, amended by guidelines 91/368/EEG, 93/44/EEG, 93/68/EEG**
- **the low voltage guideline 73/23/EEC, amended by guideline 93/68/EEG**
- **the EMC guideline 89/336/EEC, amended by guidelines 92/31/EEG, 93/68/EEG**

J.M.W. Henkelman
Managing Director



The Netherlands, s-Hertogenbosch, April 2001