

metos

ICE-CUBE MAKER

AIR-CONDENSED
WATER-CONDENSED

TYPE: CB184A, CB249A, CB316A, CB425A, CB640A, CB955A,
CB1265A, CB1565A, DSS42

Installation and Operation Manual



Dear Customer,

Congratulations on deciding to choose a Metos appliance for your kitchen activities. You made an excellent choice. We will do our best to make you a satisfied Metos customer like thousands of customers we have around the world.

Please read this manual carefully. You will learn correct, safe and efficient working methods in order to get the best possible benefit from the appliance. The instructions and hints in this manual will give you a quick and easy start, and you will soon note how nice it is to use the Metos equipment.

All rights are reserved for technical changes.

You will find the main technical data on the rating plate fixed to the equipment. When you need service or technical help, please let us know the serial number shown on the rating plate. This will make it easier to provide you with correct service.

For your convenience, space is provided below for you to record your local Metos service contact information.

METOS TEAM

Metos service phone number:.....

Contact person:.....

1. General	1
1.1 Symbols used in the manual	1
1.2 Symbols used on the appliance	1
1.3 Checking the relation of the appliance and the manual	1
2. Safety instructions	2
2.1 Safe use	2
2.1.1 Modifications	2
2.2 Safety instructions in case of malfunction	2
2.3 Disposal of appliance	2
3. Functional description	3
3.1 General	3
3.2 Designed use of appliance	3
3.2.1 Other than instructed use	3
3.3 Structure	3
3.4 Functioning principle	3
3.4.1 Switches and signal lights	3
4. Use instructions	4
4.1 Before use	4
4.1.1 Preparations	4
4.2 Use	5
4.3 After use	6
4.3.1 Cleaning	6
4.3.2 Scheduled maintenance	6
4.3.3 Layup	7
5. Installation	8
5.1 General	8
5.1.1 Positioning	8
5.2 Possible disturbances from environment (to environment)	8
5.3 Storage	8
5.4 Preparing installation	9
5.5 Unpacking	9
5.6 Disposal of packaging	9
5.7 Installation	9
5.8 Placing of appliance	10

5.9 Connection to power supply mains	10
5.10 Connection to water mains	11
5.10.1 Connection to cold water	11
5.10.2 Connection to water drain pipe	12
5.11 Distance of other fixtures	13
6. Troubleshooting	14
7. Technical specifications	17

1. General

Carefully read the instructions in this manual as they contain important information regarding proper, efficient and safe installation, use and maintenance of the appliance.

Keep this manual in a safe place for eventual use by other operators of the appliance.

The installation of this appliance must be carried out in accordance with the manufacturer's instructions and following local regulations. The connection of the appliance to the electric and water supply must be carried out by qualified persons only.

Persons using this appliance should be specifically trained in its operation.

Switch off the appliance in the case of failure or malfunction. The periodical function checks requested in the manual must be carried out according to the instructions. Have the appliance serviced by a technically qualified person authorized by the manufacturer and using original spare parts.

Not complying with the above may put the safety of the appliance in danger.

1.1 Symbols used in the manual



This symbol informs about a situation where a safety risk might be at hand. Given instructions are mandatory in order to prevent injury.



This symbol informs about the right way to perform in order to prevent bad results, appliance damages or hazardous situations.



This symbol informs about recommendations and hints that help to get the best performance out of the appliance.

1.2 Symbols used on the appliance



This symbol on a part informs about electrical terminals behind the part. The removal of the part must be carried out by qualified persons only.

1.3 Checking the relation of the appliance and the manual

The rating plate of the appliance indicates the serial number of the appliance. If the manuals are missing, it is possible to order new ones from the manufacturer or the local representative. When ordering new manuals it is essential to quote the serial number shown on the rating plate.

2. Safety instructions

2.1 Safe use

To guarantee the efficiency of the ice cube maker and to ensure its proper operation, it is essential to adhere to the directions provided by the manufacturer and to make sure that any maintenance work is carried out exclusively by professionally qualified staff. The appliance is designed to be used by adult persons. Consequently, prevent any children from gaining access to it, for example with the intention of playing with it.

2.1.1 Modifications

Modifying or attempting to modify this appliance, in addition to rendering any form of warranty null and void, is extremely dangerous.

2.2 Safety instructions in case of malfunction

Under no circumstances, attempt to repair the appliance yourself, since any intervention on the part of persons who are not competent, in addition to being dangerous, may cause serious damage to it. In the event of a failure, contact the dealer who sold you the appliance; he will be able to give you the address of your nearest Authorized Technical Service Centre. We recommend that you insist on having always and exclusively original spares.

2.3 Disposal of appliance

Should you decide to scrap your ice cube maker, first disconnect the power supply cable from the mains, and then cut the cable off. In addition, proceed as follows:

- Break and remove the door in order to prevent the possible danger of a child getting trapped inside.
- Make sure not to disperse the coolant gas and oil contained in the compressor into the environment.
- Dispose of or recover the various materials according to the requirements of current regulations valid in your country.



This appliance does not contain coolant that damages the ozone layer.

3. Functional description

3.1 General

In making ice cubes only cold, pure drinking water, should be used. Insofar ice cubes are mainly used for cooling of beverages for internal use, shall the quality of water used in making ice cubes be considered as important as the pureness and good storage of any other food products.

3.2 Designed use of appliance

Your ice cube maker is designed solely for the production of ice cubes.

3.2.1 Other than instructed use

Do not use the ice cube container to cool or preserve food or drinks, insofar as these operations could cause the drainage system to get clogged, so leading the container filling up and water leaking out. Any use of the ice cube maker other than for the production of ice cubes, from cold drinking water, is to be considered as improper use.

3.3 Structure

The supporting structure of the ice cube maker is of steel and the outer panels are of stainless steel.

3.4 Functioning principle

The coolant in the cooling system freezes the evaporator to a temperature of -15°C . A water pump sprays an even jet of water into the upside down turned cupformed evaporator, where forms solid ice. When the ice cube is large enough, starts a phase of warm gas melting, during which the ice cubes come loose from the evaporator and fall down into the ice cube container. When the ice cubes reach the level of a probe in the container, the ice forming terminates. When the level of the ice cubes falls under the level of the probe, then ice forming restarts automatically.

3.4.1 Switches and signal lights

The CB ice cube maker have a green switch on the front panel switches ON and OFF the appliance.

4. Use instructions

4.1 Before use

4.1.1 Preparations



The ice cube maker has been already cleaned in the factory. However you are advised to wash the internal parts again before using the appliance.



When you start up the ice cube maker the first time, after service or when you start it up after a long period of layoff, pour 3 litres of water into the internal basin (see fig.). This filling operation must be carried out by raising the flaps and pouring the water directly into the internal basin.

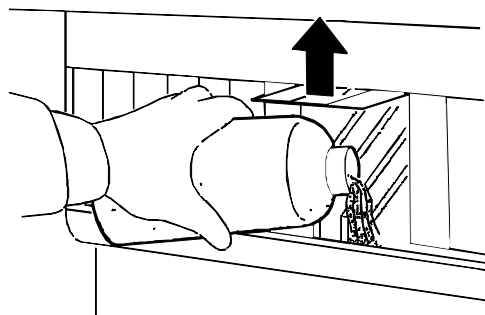

At other times the water runs automatically and the previous procedure is not necessary.

After that, open the water supply tap, insert the plug in the electric supply socket and switch on the power supply.

Ice cube dispenser DSS:

Turn on the water supply tap and switch on the power supply.

Remove the plug on the front grid panel. Using a screwdriver turn the adjuster screws of the timer clockwise (see fig.) until you hear a click and the water pump stops.

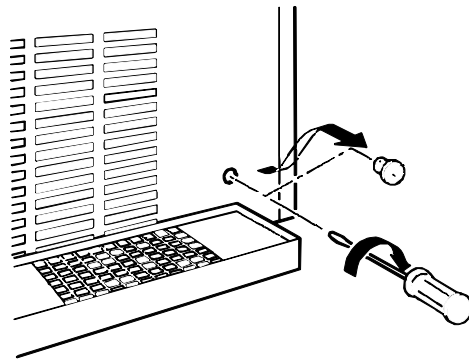

Repeat this operation three times, keeping one minutes pause between regulations.

Fit up the plug back on the front grid.

The appliance will automatically start producing ice.

4.2 Use



In the normal daily use the ice cube maker functions until the ice cubes reach a probe in the container. When any ice is taken from the container and the level of ice cubes falls under the probe level, then ice cube production will be reactivated automatically.



In making ice cubes only cold, clean drinking water should be used. Insofar ice cubes are mainly used for cooling of beverages for internal use, shall the quality of water used in making ice cubes be considered as important as the pureness and good storage of any other food products.



Never use the ice cube container for cooling or storing of food products or beverages, because this may cause an obstruction in the drain for the melt water, which would cause an overflow of water in the ice cube container.

Ice cube dispenser DSS:

The appliance is equipped with an ice cubes dispenser on the front.

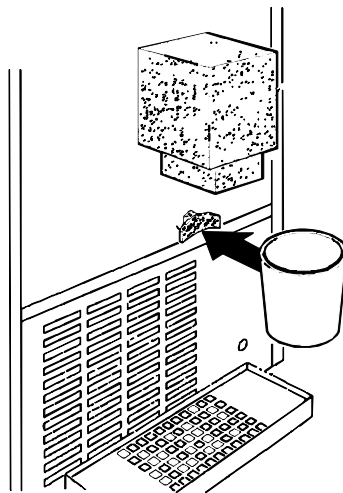

To take the require quantity of ice, put a glass or a suitable container under the dispenser and press the button to turn on the supply. Release the button to stop the ice supply.

4.3 After use

4.3.1 Cleaning



All cleaning operations must be carried out only after the power and water supply have been disconnected as described previously.



For cleaning operations in general use an ordinary detergent for washing dishes or a solution of water and 10 % of vinegar. To eliminate sediment, use a soft plastic-bristle brush and a sponge. You are recommended not to use abrasive detergents or powders, since these might damage the finishings.



Internal parts cleaning and disinfecting can be carried out only by the authorized technical service centers.



For air-cooled models, it's very important to keep the finned condenser clean.

Have the finned condenser cleaned at least once every two months by authorized technical service center, which can include this operation in the scheduled maintenance program.

4.3.2 Scheduled maintenance

We recommend that you ask your dealer to draw up a scheduled maintenance contract which will cover the following:

- cleaning of the condenser every two months
- cleaning of the filter located on the water inlet solenoid valve every two months
- check on state of charge of the coolant gas 2 x year
- check of operating cycle 2 x year
- disinfection of the ice cube maker 2 x year.

4.3.3 Layup

If you do not intend using the ice cube maker for a certain period of time, proceed as follows:

1. Unplug the power cable from the socket.
2. Shut off the water supply by turning off the tap provided during installation.
3. Carry out all the operations envisaged for scheduled maintenance of the appliance.
4. Empty out the pump body by blowing compressed air into the pipe carrying the water to the spray ramp.

5. Installation

5.1 General

The ice cube maker is delivered attached to a special wooden pallet and protected with cardboard packaging.



Installation must be carried out exclusively by qualified and authorized staff, in compliance with current national standards and following the manufacturer's instructions.

5.1.1 Positioning

The best performance of the ice cube maker is achieved at a room temperature of between 10°C and 35°C and a water supply temperature of between 3°C and 25°C. Consequently, avoid installing the appliance where it may be exposed to direct sunlight or near to heat sources, such as radiators, stoves, dish-washers, etc.



This appliance must not be used outside, must not be installed in damp places or where it is liable to be sprayed with water. The appliance must be positioned at a distance of at least 5 cm from the side walls.

5.2 Possible disturbances from environment (to environment)

If installation is carried out incorrectly, damage and/or injury may ensue to the environment, persons, animals or things. The manufacturer declines all responsibility for any such damage or injury.

5.3 Storage

The net weight and the weight including packaging of the ice cube maker are given on the cover of the packaging. In order to prevent the oil contained in the compressor from flowing into the coolant circuit, make sure to transport, store, and handle the ice cube maker always keeping it standing upright. Follow the instructions given on the packaging.

The special wooden pallet, built so that it can be lifted with a fork-lift truck, enables the appliance to be moved around using ordinary means of handling and lifting.

5.4 Preparing installation

Make sure, that the ice cube maker will be installed on an even surface. Avoid installing the appliance near heat sources. A floor drain should be found near of the place of installation. The maximum distance being 5 m. Make sure that the melt water hose presents a slope of at least 5 % throughout its entire length.

5.5 Unpacking

Remove the cardboard packaging by cutting the straps that hold it in place; then slide it off from the top.



Once you have removed the packaging, make sure that the ice cube maker is in perfectly good condition. If you are in any doubt, do not use it and contact immediately the dealer who sold it to you.

Rest the wooden pallet on the floor and loosen and remove the screws that fix the appliance to the pallet.

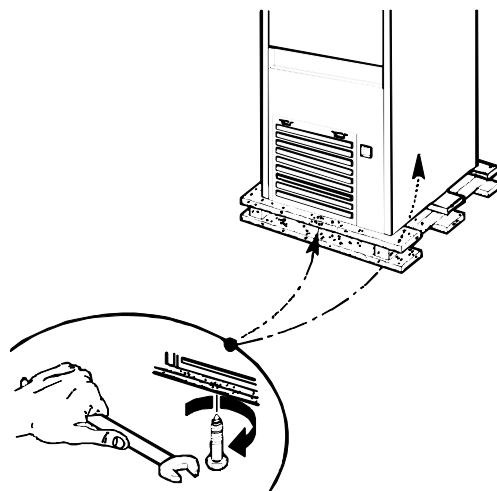

5.6 Disposal of packaging

All the packaging items (plastic bags, cardboard, polystyrene foam, nails, etc.) must not be left within reach of children, in that they are potential sources of danger.

5.7 Installation

Once you have completed the above operations, lift the ice cube maker off the wooden pallet and screw on the feet supplied in a plastic bag in the ice cube container. Use a spirit level to check that the appliance is standing perfectly level. If necessary, adjust the feet (see fig.).

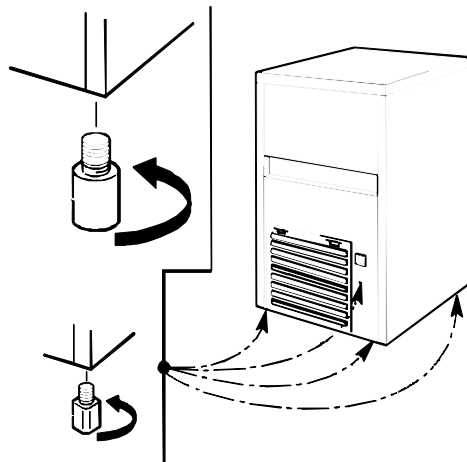

5.8 Placing of appliance

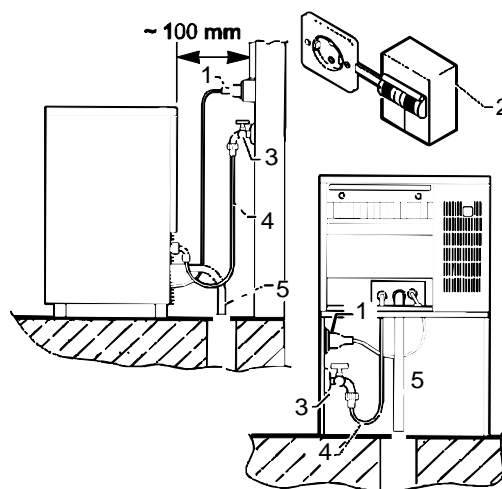

1. Plug
2. Socket with switch
3. Water tap
4. Water supply pipe
5. Water drain pipe

5.9 Connection to power supply mains

The electrical wiring system scheme is attached inside of the front panel of the ice cube maker.

To reach this, unplug the power cable from the socket, unscrew the screws, which fasten the front panel and slide it away.

Electric safety of the ice cube maker is achieved solely when the appliance is properly connected to an efficient earthing system made in compliance with current national safety standards. Make sure that this fundamental safety requirement is respected and, if you are in any doubt, ask for a thorough check of the electric system by professionally qualified and authorized staff. The manufacturer declines all responsibility for damage and/or injury that might ensue from any failure to earth the system properly. It is essential that the electrical wiring system where the appliance is to be installed should have adequate current carrying capacity for the maximum power of the appliance, as shown on the data plate. To achieve a proper and safe installation of the ice cube maker, it is necessary to provide an appropriate earthed socket, with a contact-opening gap of no less than 3 mm, in accordance with current national safety standards. This switch must moreover be equipped with fuses.

Make sure to unroll the power supply cable to its entire length and check that it is not squeezed in any way.

5.10 Connection to water mains

5.10.1 Connection to cold water

The ice cube maker is designed solely for producing ice cubes and must be fed exclusively with cold water for human consumption (drinking water).

The running pressure must be between 1-6 bar.

Connection to the water mains must be made following the manufacturer's instructions by professionally qualified staff.

Between the water mains and the charge pipe of the ice cube maker, a tap must be installed so that the water supply may be shut off if need be.



Never turn the water supply tap off when the appliance is working.

Where the feed water is particularly hard, you are advised to install a softener. Any solid particles (e.g., sand) may be eliminated by installing a mechanical filter, which must be periodically inspected and cleaned. These filters must be in compliance with the relevant national standards in force.

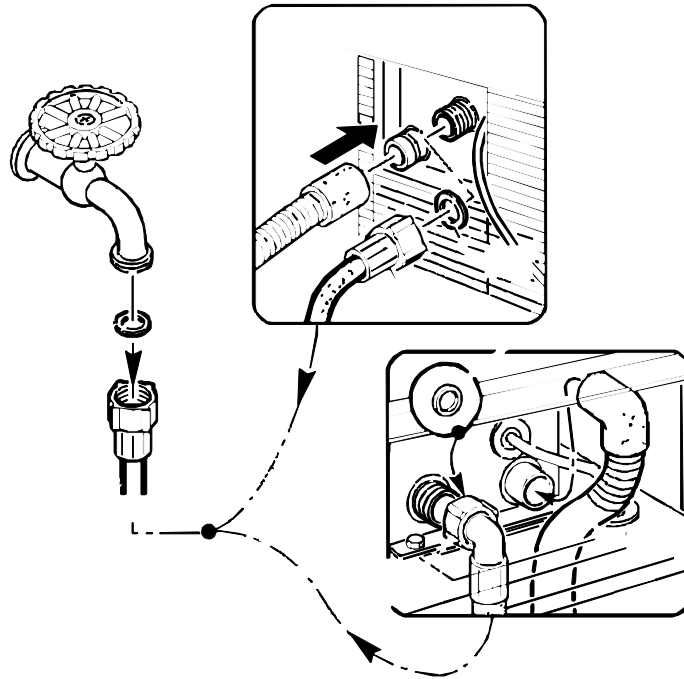

Insert the special gaskets provided in the two threaded ring nuts of the water pipe supplied with the appliance.

Without exerting excessive force in order not to risk cracking the unions, firmly tighten a threaded ring nut on the outlet of the solenoid valve located in the back of the ice cube maker. The other threaded ring nut must be screwed to the water tap, this must be provided with a thread too.

5.10.2 Connection to water drain pipe

Fix the water drainage pipe in the housing provided on the back of the appliance.

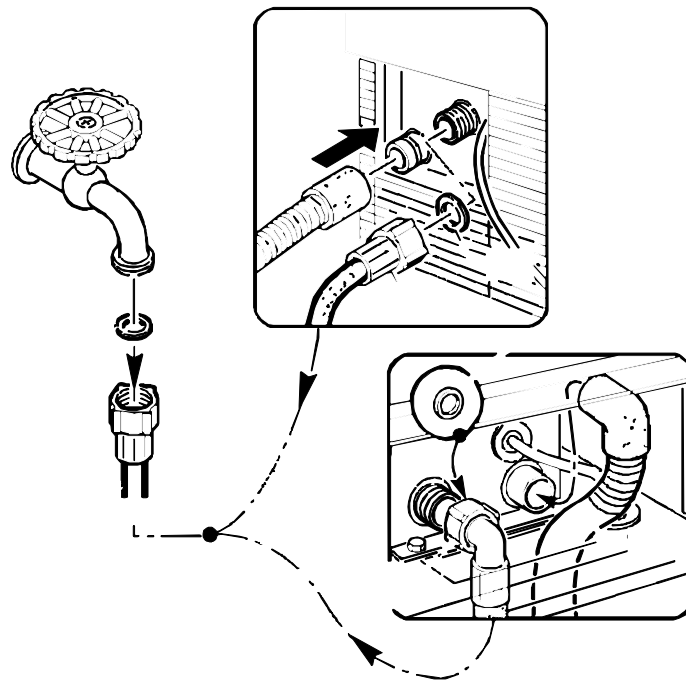

Make sure that:

- The internal diameter of the hose is 22 mm.
- The water-discharge hose is not throttled in any point throughout its length.
- The discharge hose presents a slope of at least 5 % on its entire length and there are no air pockets in the hose.
- Lead the discharge hose into an open drain trap, head of the pipe must stay over an drain trap.

5.11 Distance of other fixtures

Do not obstruct the ventilation and heat-dissipation grids, since poor air conditioning, in addition to reducing efficiency and causing poor operation, may also cause serious damage to the appliance.

Leave distance at least 50 mm from the sides and 100 mm from the back of the ice cube maker, to make sure that air conditioning is sufficient.

6. Troubleshooting

Should the appliance fail to produce ice, before calling on the Authorized Technical Service Centre, first check carefully that:

- The water supply tap provided in the installation phase is open.
- The electric power is reaching the appliance, the plug is properly inserted, and the power switch is in the “on” position.
- In the event of excessive noise, check that the appliance does not come into contact to next fixtures, that may cause noise or vibrations.
- Should any traces of water appear, check that the discharge hole of the container is not obstructed, that the water feed and discharge pipes are correctly installed up and do not present any throttling or damage.
- Make sure that the temperature of the air or water does not exceed the installation limit values.
- Make sure that the water inlet filter is not clogged.
- Make sure that the spray nozzles are not clogged with scaly deposits.

Once the above checks have been made, if the appliance were still to present malfunctioning, switch off the power supply, pull out the plug from its socket, close the water tap connecting the appliance up to the water supply, and call the nearest Authorized Technical Service Center.

In order to obtain a faster and more efficient intervention, when you call the Center, indicate the model of the apparatus precisely, and its serial number. These can be read on the matriculation lable stuck on the rear of the appliance or on the cover of this manual.

MALFUNCTION	Possible cause	Operation
Ic -cube maker does not function	Appliance does not function	Check power supply
	Thermostat in the container does not func.	Change the thermostat
	Safety thermostat of the condenser does not function.	Change the thermostat
	Safety pressure switch has cut off (C300)	Settle the pressure switch
	Contactore does not function/burned down	Change contactore
Appliance functions, but does not make proper ice	There is no coolant gas	Find leakage, fix it, vacuumize and fill up
	Warm gas valve leaks	Fix or change the valve
	Compressor does not pump	Change the compressor
	Air condensed models	Check the fan, change if needed
	Condenser fan does not function	Check the function. of the pressure switch
Water basin receives no water	Solenoid valve does not open or is blocked	Change the valve
	Slide pulse does not open the valve	Change the slide pulse

Troubleshooting

Water basin has no water or water runs out during cycle	Overflow pipe of the basin is not at the right place	Set the pipe on the right level or renew it
	Dirty nozzles	Clean or change the nozzles
	Water basin leaks	Find the leakage and fix/change the basin
	Sieve of the water valve is blocked	Clean the sieve
Water spraying does not function	The water pump does not function	Check the pump, change if needed
	The suction sieve of the water basin is obstructed	Clean the sieve
	The waterpipes are obstructed	Clean the waterpipes
	The nozzles are obstructed	Clean the nozzles
Appliance does not stop when the container is filled	The thermostat of the ice-cube container	Check the probe, adjust/change the thermostat
Safety thermostat for overheating stops the appliance	The water supply valve does not open	Change the pressure switch
		Check the valve, change if needed
	The water condenser is obstructed	Clean the water condenser (slime removal)
	The apparatus receives no water	Check the water supply
Appliance stays in function during the cooling phase	Malfunctioning thermostat of the evaporator	Change the thermostat
	The reel of the warm gas cooling valve	Change the reel
	The slide pulse is stuck	Change the slide pulse
	The curtain is in wrong way	Change the curtain in right way
Collects ice under the evaporator or frozes throughout	Malfunctioning thermostat of the evaporator	Change the thermostat
	Warm gas valve leaks	Change valve
	The slide pulse is stuck	Change the slide pulse
	The apparatus has not enough liquid	Find leakage, fix it, vacuumize and fill up
Irregular or incomplete melting	Lack of water	Check water supply of the evaporator
	Not enough liquid	Find leakage, fix it, vacuumize and fill up
	Dirty evaporator	Clean the evaporator (cautiously)
	The water valve does not get closed	Change the valve
Change the RC-cover of the pressure switch		
Lack of water	Water supply or drain pipe is not connected	Check the connections
	The water pump leaks	Change the pump
	Bad pipe connections	Check the pipe connections
	Plastic drain water coupler is broken	Check fix/change
Irregular ic -cubes	Lime containing water	
	The nozzles are improperly directed	Aim the water jet in the middle of the cup
Noisy or leaking water pump	Malfunctioning bearings	Change the pump
	Mounting of of the pump/plate is loose	Check the attachment of the pump
	Malfunctioning axial seal	Change the pump
	Seal in the pump chamber leaks	Change pump

Troubleshooting

Compressor is noisy or functions irregularly	Malfunctions in the electrical system	Check the electrical system
	Start condenser is malfunctioning	Change the condenser
	Start relay is malfunctioning	Change the relay
	Uneven start	Change the compressor
	Shakes at start up	Change the compressor
	Extremely noisy functioning	Change the compressor
Water pump does not function	Malfunctioning electrical system	Check the mikroswitches of the slide pulse
	Electric potential disturbance	Change the pumps run condenser
	The pump is mechanically stuck	Fix or renew the pump
	The pump makes stops	Renew the pump
Ice cube production reduces	The condenser or the air filter is obstructed	Clean the condenser or the filter
	The water does not exit from the ice container	Drain water hose is throttled/blocked
	Not enough liquid	Find leakage, fix it, vacuumize and fill up
	The warm gas valve leaks	Fix or renew the valve
	The water valve leaks or changes the water	Renew the water solenoid valve
	The suction valves of the compressor leak	Renew the compressor
Melting phase does not function	Warm gas valve does not open	Check the valve, fix it or renew

7. Technical specifications

Electric diagram 24459 (valid from 2004.01.28)

Electric diagram 24312 rev 03 (valid from 2004.01.28)

Electric diagram 24313 rev.4 (valid from 2004.07.22)

Electric diagram 24314 rev 03 (valid from 2004.07.22)

Electric diagram 24315 (valid from 2003.02.10)

Electric diagram 24158

Installation diagram CB184 (valid from 2003.02.10)

Installation diagram CB249

Installation diagram CB316 & CB425

Installation diagram CB640 & CB955

Installation diagram CB1265 & CB1565

Installation diagram DSS42

Marine foot

VIRTAPIIRIKAAVIO / ELECTRIC DIAGRAM

1. TERMOSTAATTI, ALLAS SAFETY THERMOSTAT	9. TERMOSTAATTI SAFETY THERMOSTAT
2. TERMOSTAATTI, HÖYRYSTIN EVAPORATOR THERMOSTAT	10. PAINEKYTKIN PRESSURE SWITCH
3. AJASTIN TIMER	12. ON-OFF KYTKIN (VIHREÄ) ON-OFF SWITCH (GREEN LIGHT)
4. KOMPRESSORI COMPRESSOR	
5. VENTTIILI, KUUMAKAASU HOT GAS VALVE	
6. HÖYRYSTIMEN VESIVENTTIILI WATER INLET VALVE FOR EVAPORATOR	B = VALKOINEN / WHITE BL = SININEN / BLUE BN = VALKO-MUSTA / WHITE-BLACK G = HARMAA / GREY M = RUSKEA / BROWN N = MUSTA / BLACK R = PUNAINEN / RED RN = PUNA-MUSTA / RED-BLACK RS = ROSA / PINK
7. PUMPPU PUMP	
7a. PUHALINMOOTTORI FAN MOTOR	
8. VESIVENTTIILI LAUHDUTTI- MELLE WATER INLET VALVE FOR CONDENSER	# 6 = RANCO K59 # 2 = ATEAA33 -RANCO K61 - RANCO K22

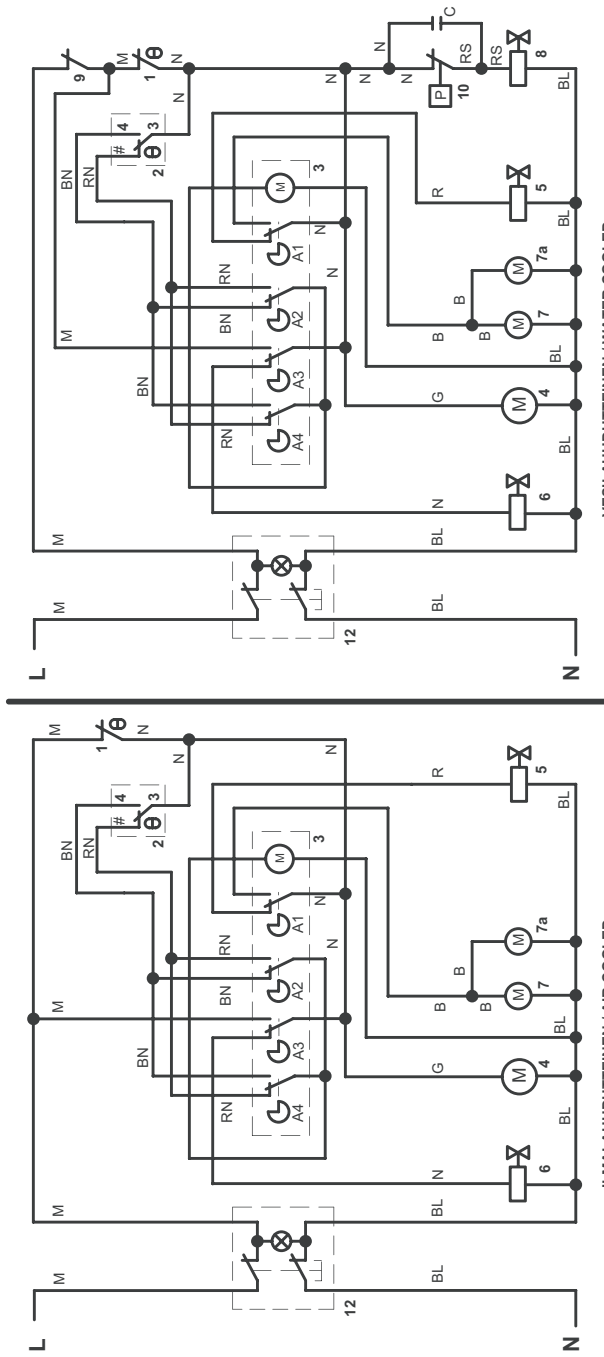

CB 184
VESILAUHDUTTEINEN / WATER COOLED

24459.pdf

Cod. 24459 - Rev. 01

VIRTAPIIRIKAAVIO / ELECTRIC DIAGRAM

1. TERMOTAATTI, ALLAS THERMOSTAT	10. PAINEKYTKIN PRESSURE SWITCH
2. TERMOSTAATTI, HÖYRYSTIN EVAPORATOR THERMOSTAT	12. ON-OFF KYTKIN (VIHREÄ) ON-OFF SWITCH ON-OFF (GREEN LIGHT)
3. AJASTIN TIMER	
4. KOMPRESSORI COMPRESSOR	
5. KUUMAKAASUVENTTILI HOT GAS VALVE	B = VALKOINEN / WHITE BL = SININEN / BLUE BN = VALKO-MUSTA / WHITE-BLACK M = HARMAA / GREY N = MUSTA / BLACK RN = PUNA-MUSTA / RED-BLACK RS = ROSA / PINK
6. VESIVENTTILI HÖYRYSTIMELLE WATER INLET VALVE FOR EVAPORATOR	
7. PUMPPU PUMP	
8. VESIVENTTILI LAUHUTTIMELLE WATER INLET VALVE FOR CONDENSER	
9. TERMOSTAATTI SAFETY THERMOSTAT	# 6 = RANCO K59 # 2 = ATEAA33 - RANCO K61 - RANCO K22

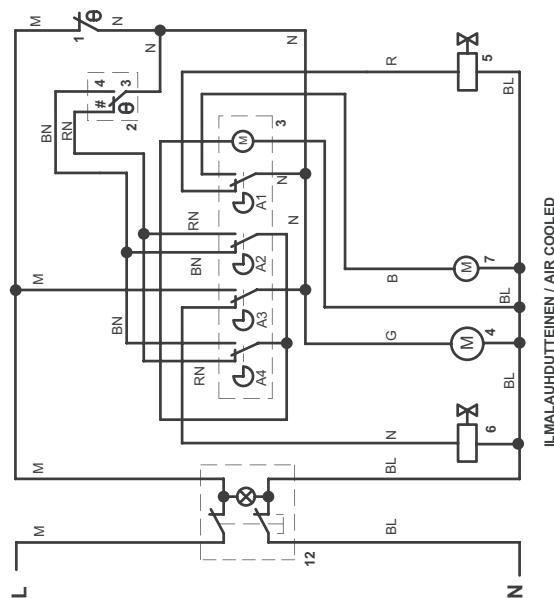

ILMALAUHDUTTEINEN / AIR COOLED

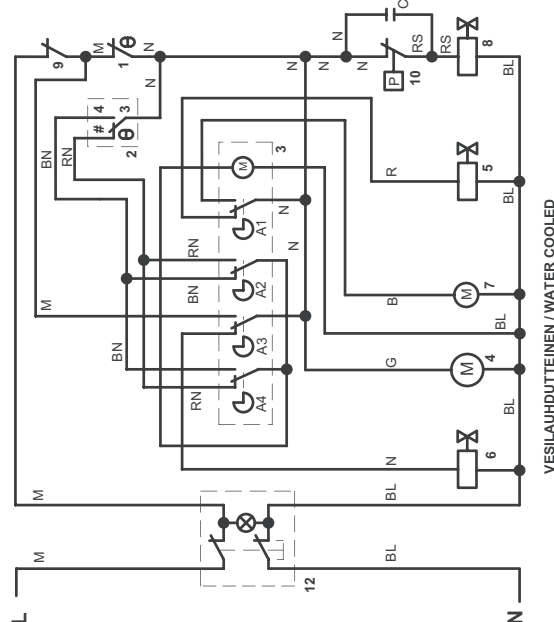

VESILAUHDUTTEINEN / WATER COOLED

24312.PDF

CB 249, CB 316, CB 425

Cod. 24312 - Rev. 03

VIRTAPIIRIKAAVIO / ELECTRIC DIAGRAM

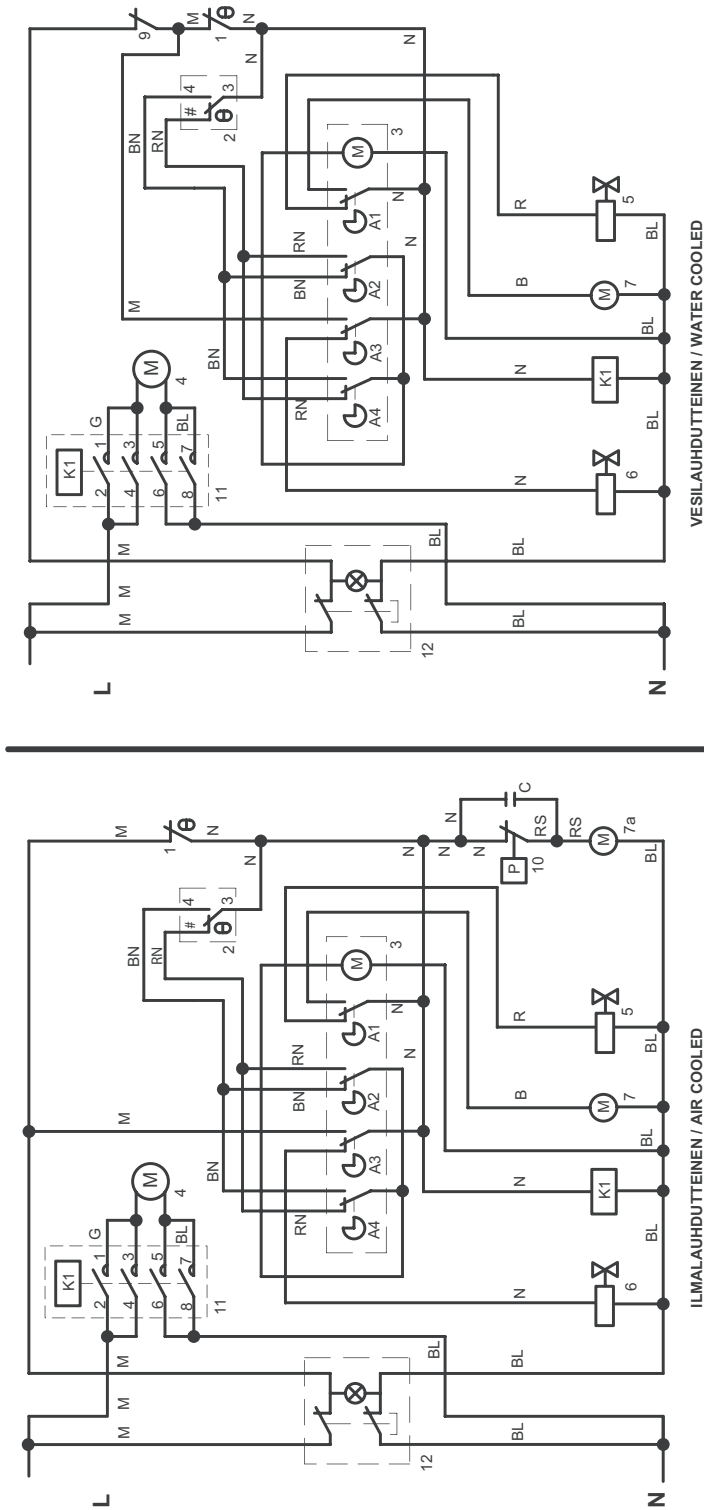

1. TERMOSTAATTIALLAS BIN THERMOSTAT	5. KUIJAKAASUVENTTILI HOT GAS VALVE	9. TERMOSTAATTI SAFETY THERMOSTAT
2. TERMOSTAATTIHÖYRYSTIN EVAPORATOR THERMOSTAT	6. HÖYRYSTIMEN VESIVENTTILI WATER INLET VALVE FOR EVAPORATOR	10. PRESSOSTAATTI PRESSURE SWITCH
3. AJASTIN TIMER	7. PUMPPUA PUMP	11. KONTAKTORI CONTACTOR
4. KOMPRESSORI COMPRESSOR	7a. PUHALINMOOTTORI FAN MOTOR	12. ON-OFF KYTKIN (VIHREÄ) SWITCH ON-OFF (GREEN LIGHT)

B = VALKOINEN / WHITE
BL = SININEN / BLUE
BN = VALKOMUSTA/WHITE-BLACK
G = HARMAA / GREY
M = RUSKEA / BROWN
N = MUSTA / BLACK
R = PUNAINEN / RED
RN = PUNA-MUSTA/RED-BLACK
RS = ROSA/PINK

6 = RANCO K59
2 = RANCO K22

Cod. 24313 - Rev. 04

VIRTAPIIRIKAAVIO / ELECTRIC DIAGRAM

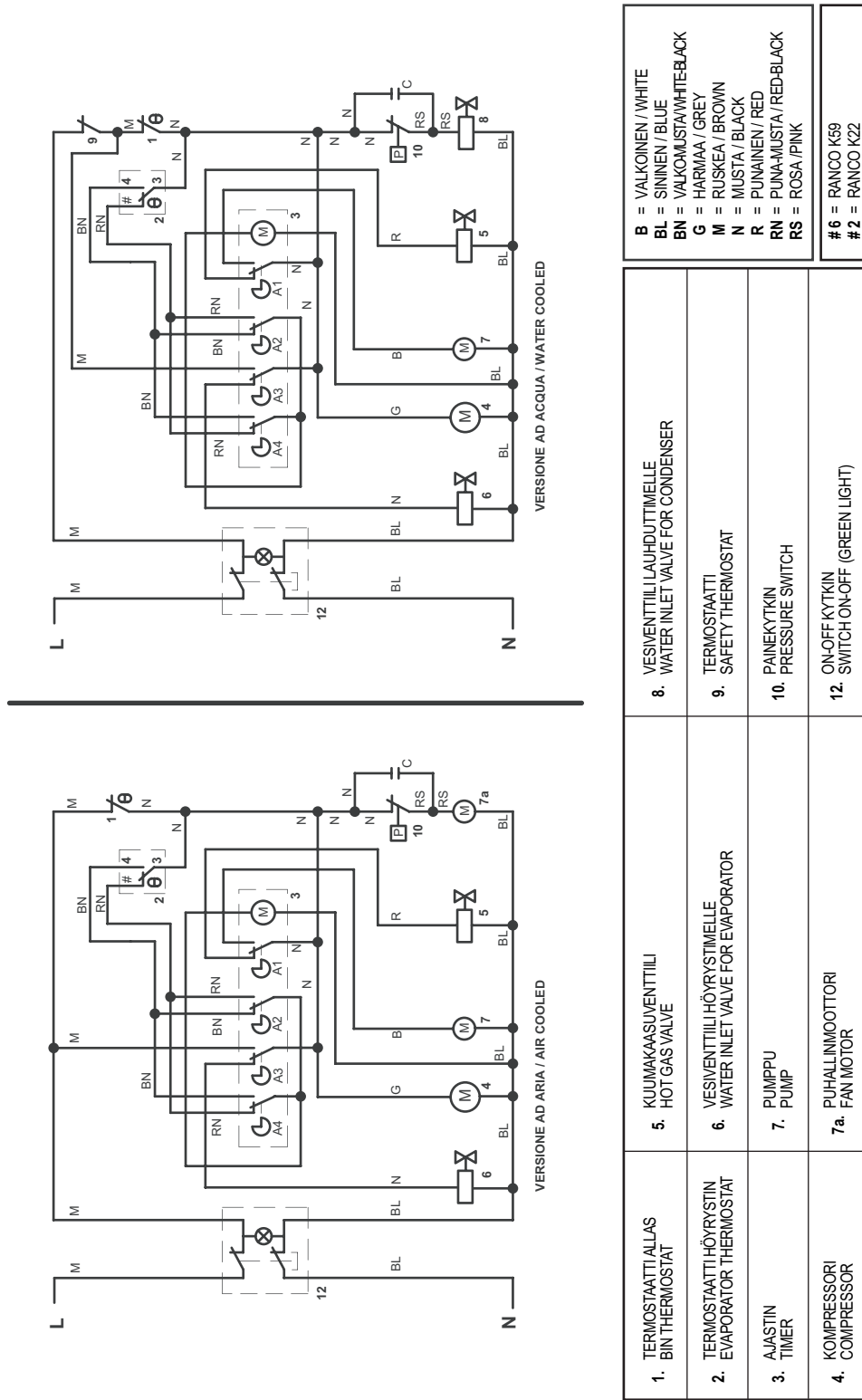

24314.PDF

CB 640, CB955, CB 1265

Cod. 24314 - Rev. 03

ELECTRIC DIAGRAM / SÄHKÖKAAVO/ELSHEMA

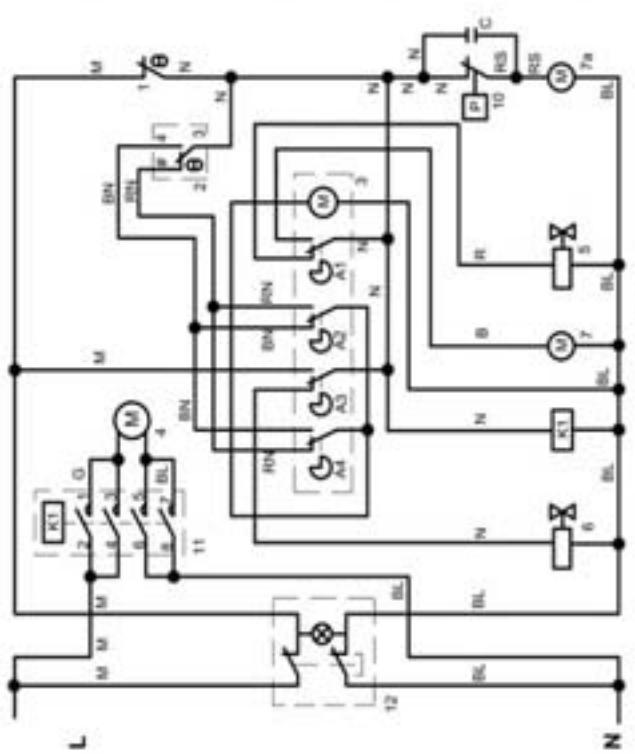

AIR COOLED
ILMAJÄÄHDYTYSTEINENLUFTKYYLD

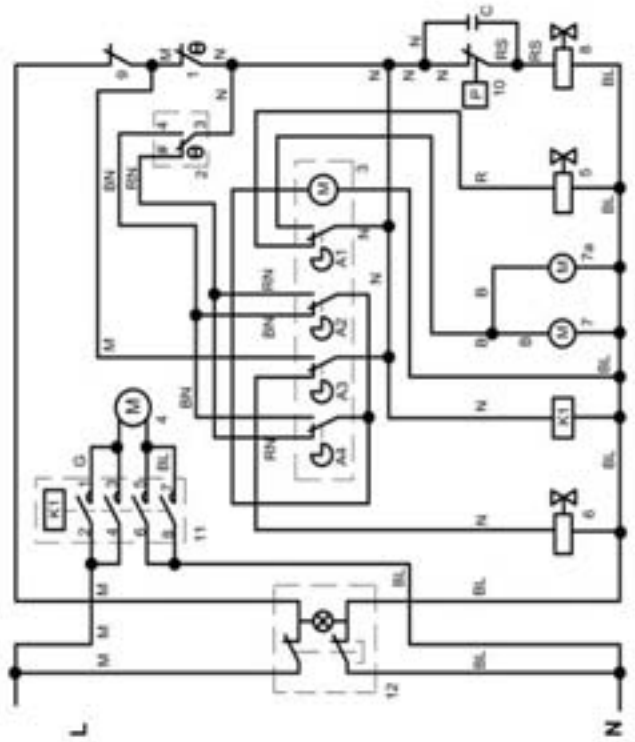

WATER COOLED
VESIJÄÄHDYTYSTEINENVAATTENKYYLD

1. BIN THERMOSTAT SÄILÖN TERMOSTAATTI BEHÄLLARENS TERMOSTAT	6. WATER INLET VALVE FOR EVAPORATOR HOYRYSTIMEN VESIVENTTILI EVAPORATORIN VÄTTENINLÖPPSVENTIL	10. PRESSURE SWITCH PAINEKYTKIN PRESSOSTAT
2. HOYRYSTIMEN TERMOSTAATTI EVAPORATOR TERMOSTAT	7. PUMPPU PUMPP	11. CONTACTOR KONTAKTORI
3. AJASTIN TIDGIVARE	7a. FAN MOTOR LAUHDUTINMOOTTORI FLÄKT MOTOR	12. SWITCH ON-OFF (GREEN LIGHT) ON-OFF KYTKIN (VHIREA) ON-OFF-BRYTTARE (GRÖN)
4. COMPRESSOR KOMPRESSORI KOMPRESSOR	8. WATER INLET VALVE FOR CONDENSER LAUHDUTTIMEN VEDEN TULOVENTTILI KONDENSORIN VÄTTENINLÖPPSVENTIL	
5. HOT GAS VALVE KUIJAKAASUVENTTILI HETGASVENTIL	9. SAFETY THERMOSTAT TURVATERMOSTAATTI SÄKERHETS TERMOSTAT	

- B = WHITE/VALKOKINEN/VIT
- BL = BLUE/SININEN/BLÅ
- BN = WHITE/BLACK/VAL-MU/VIIT-SV
- G = GREY/HARRMAA/GRÅ
- M = BROWN/RUSKEA/BRUN
- N = BLACK/MUSTA/SVART
- R = RED/PUNAINEN/ROD
- RN = RED-BLACK/PUN-MUIRODISV
- RS = PINK/VAALEAN/PUNAINEN

- # 6 = RANCO K59
- # 2 = ATEA A33 - RANCO K61

Cod. 24315 - Rev. 02

ELECTRIC DIAGRAM / SÄHKÖKAAVIO / ELSKEMA

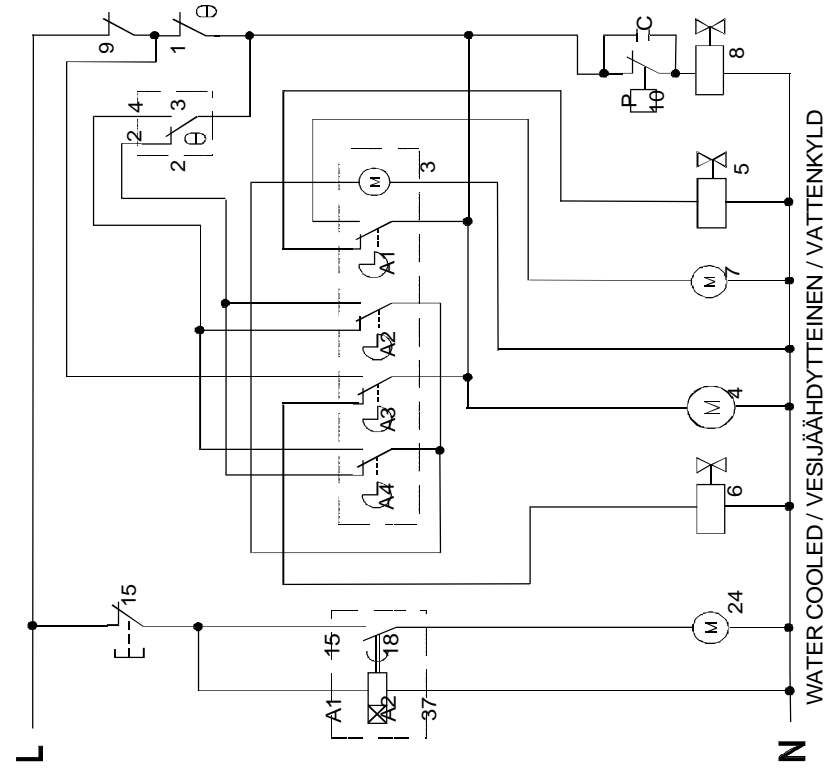
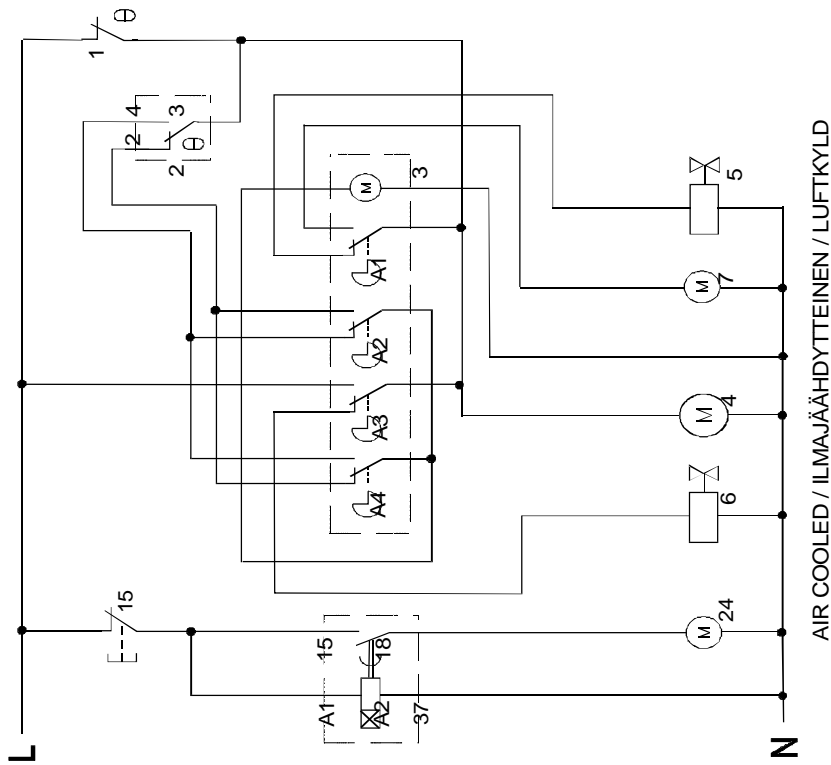

1. TANK THERMOSTAT SÄILÖN TERMOSTAATTI TANK THERMOSTAT	6. WATER INLET VALVE FOR EVAPORATOR HÖYRYSTIMEN VESIVENTTIILI VATTENS INLOPPSVENTIL TILL EVAPORATOR	15. MICRO SWITCH NORMALLY CLOSED MIKROKYTKIN NORMAALISTI SULJETTU MIKRO-BRYTARE NORMALT STÄNGD
2. EVAPORATOR THERMOSTAT HÖYRYSTIMEN TERMOSTAATTI EVAPORATOR TERMOSTAT	7. PUMP + FAN PUMPUU + TUULETIN PUMPA + FLÄKT	24. ICE CUBES DELIVERY GEAR MOTOR JÄÄPALA-ANNOSTELUAN KONEISTON MOOTTORI ISKUBUTMATINGS VERK MOTOR
3. TIMER AJASTIN TIDGIVARE	8. WATER INLET VALVE FOR CONDENSER LAUHDUTTIMEN VEDEN TULOVENTTIILI VATTENS INLOPPSVENTIL TILL KONDENSOR	37. ICE DELIVERY TIMER JÄÄANNOSTELUN AJASTIN ISUTMATNING TIDGIVARE
4. COMPRESSOR KOMPRESSORI KOMPRESSOR	9. SAFETY THERMOSTAT TURVATERMOSTAATTI SÄKERHETS TERMOSTAT	DSS42AW 220/50-60
5. HOT GAS VALVE KUUUMA KAASU VENTTIILI VARM GAS VENTIL	10. PRESSURE SWITCH PAINEKYTKIN PRESSOSTAT	COD. 24158 REV.01

Installation diagram CB184 (valid from 2003.02.10)

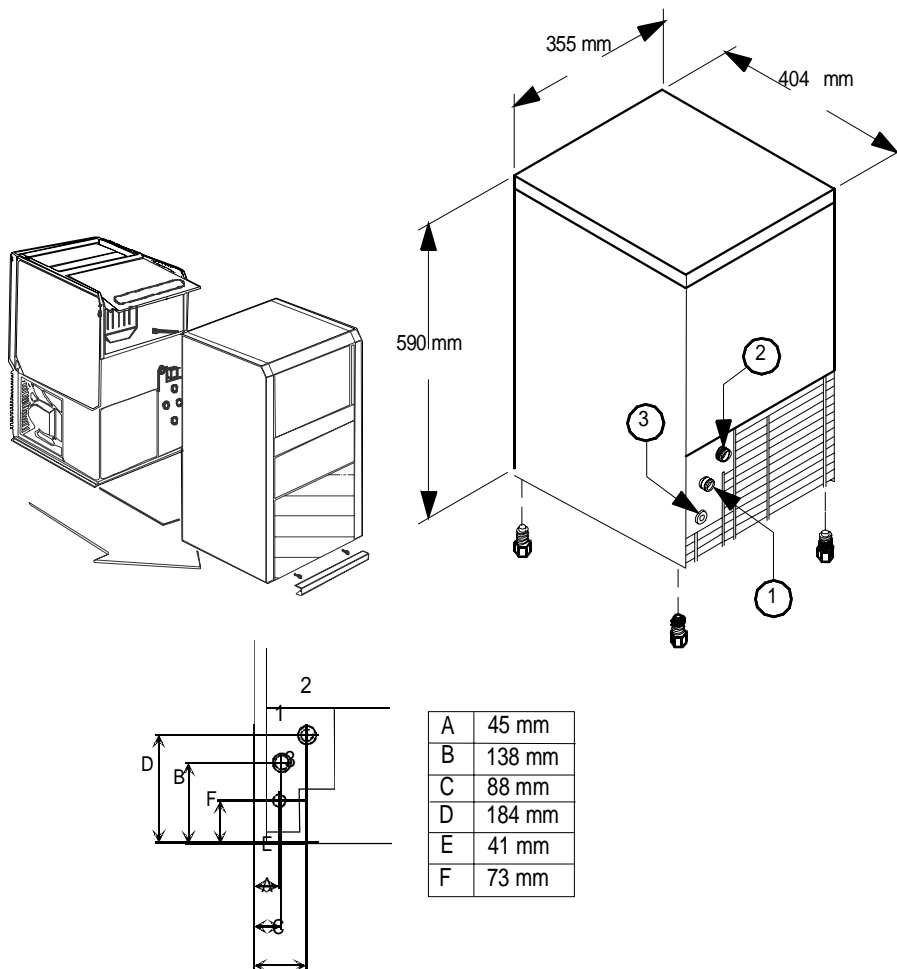

1. Water drain pipe, diam. 24mm
2. Cold water connection, diam. 3/4" external thread
3. Electric connection



Look, Installation, place; Placing of appliance[184]

Installation diagram CB249

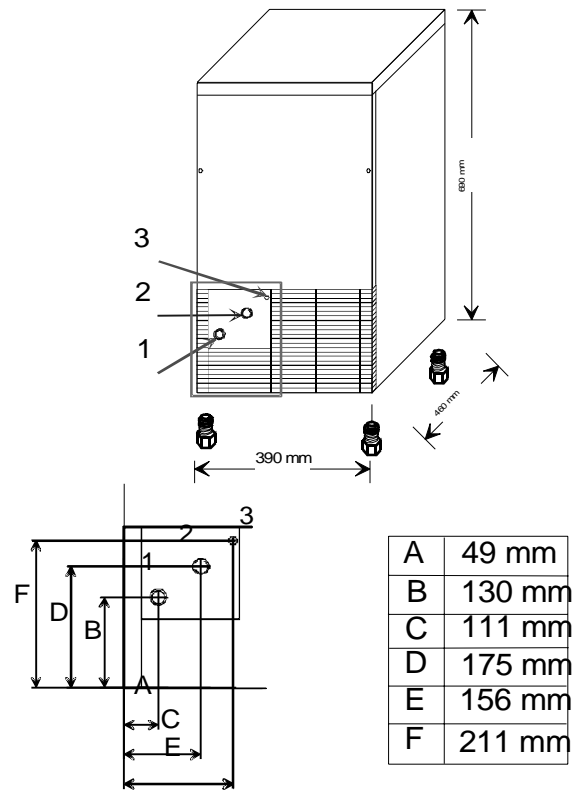

1. Water drain pipe, diam. 24mm
2. Cold water connection, diam. 3/4" external thread
3. Electric connection



Look, Installation, place; Placing of appliance[249]

Installation diagram CB316 & CB425

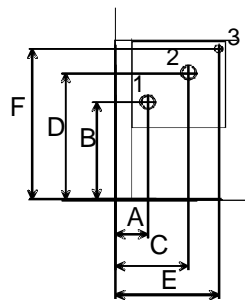
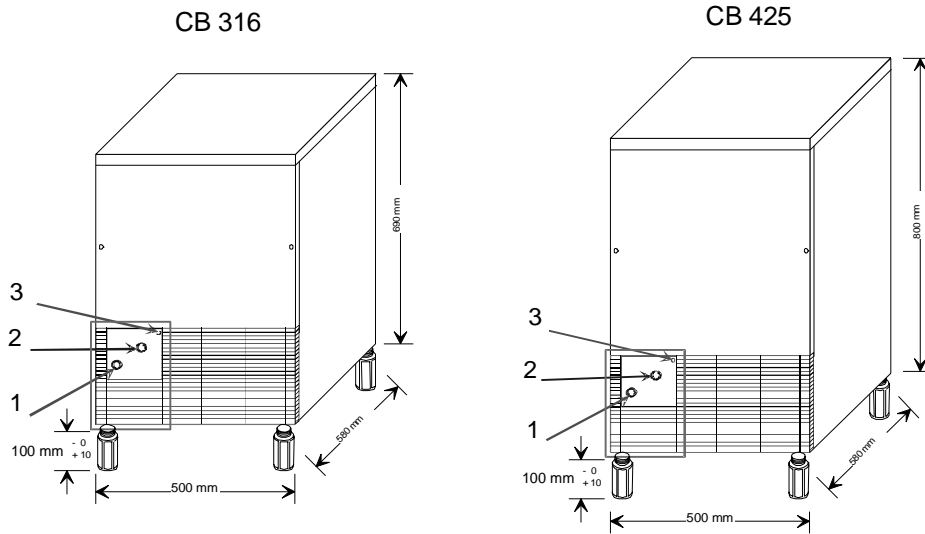

A	49 mm
B	151 mm
C	111 mm
D	196 mm
E	156 mm
F	232 mm

1. Water drain pipe, diam. 24mm
2. Cold water connection, diam 3/4" external thread
3. Electric connection



Look, Installation, place; Placing of appliance[316,425]

Installation diagram CB640 & CB955

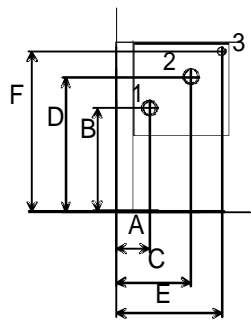
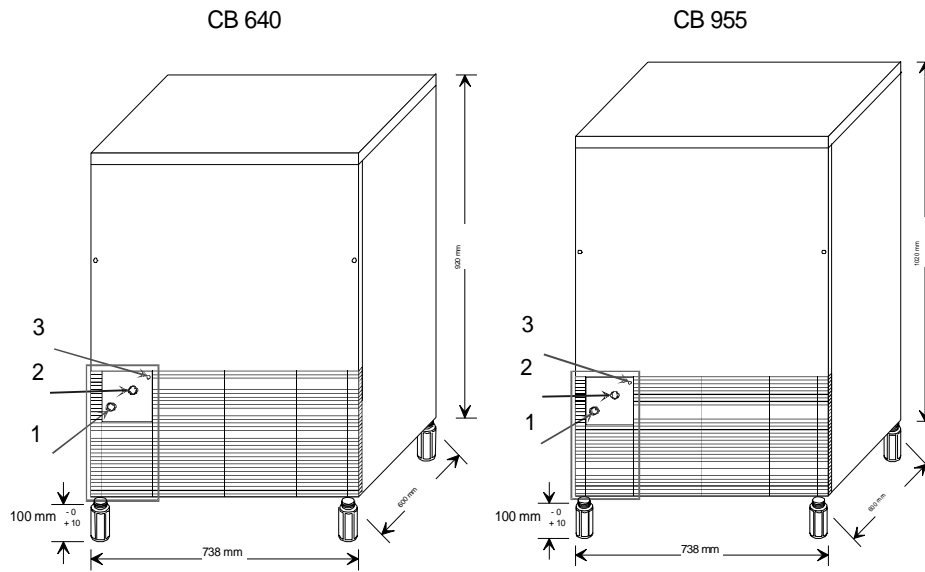

A	54 mm
B	240 mm
C	116 mm
D	285 mm
E	161 mm
F	321 mm

1. Water drain pipe, diam. 24mm
2. Cold water connection, diam. 3/4" external tread
3. Electric connection



Look, Installation, place; Placing of appliance[640,955]

Installation diagram CB1265 & CB1565

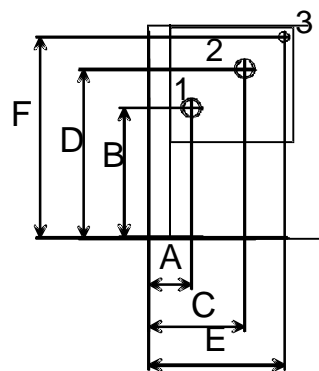
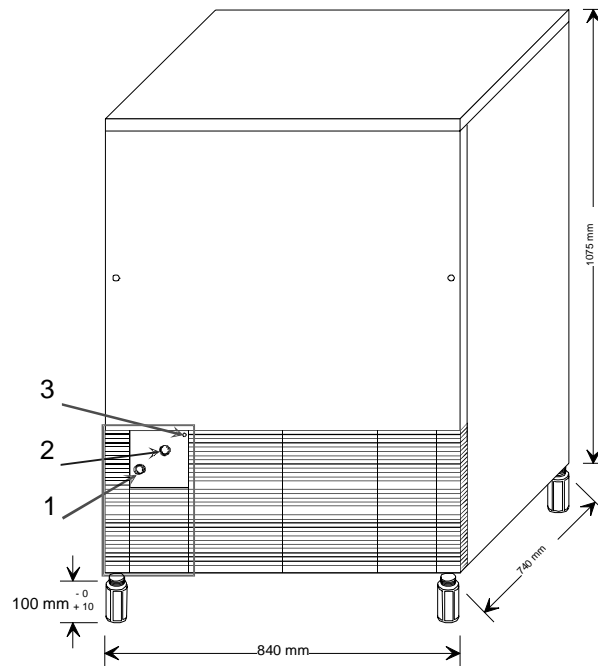

A	79 mm
B	245 mm
C	141 mm
D	290 mm
E	186 mm
F	326 mm

1. Water drain pipe, diam. 24mm
2. Cold water connection, diam. 3/4" external thread
3. Electric connection



Look, Installation, place; Placing of appliance[1265,1565]

Installation diagram DSS42

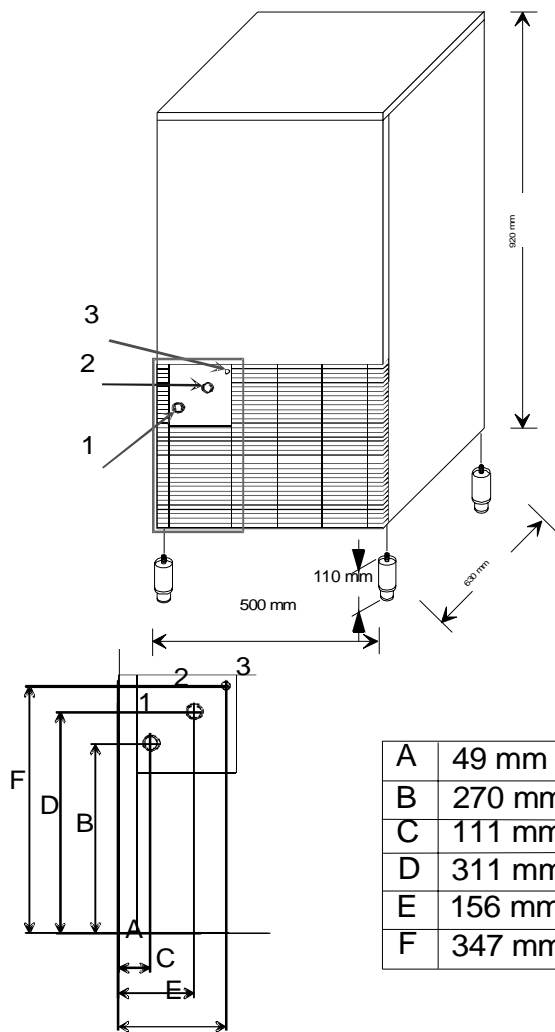

1. Water drain pipe, diam. 24mm
2. Cold water connection, diam. 3/4" external thread
3. Electric connection



Look, Installation, place; Placing of appliance[42]

New marine foot

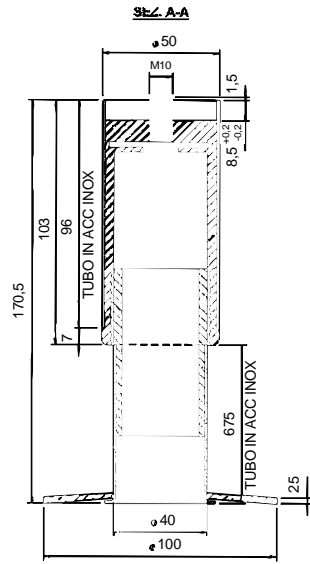

Installation of marine foot:

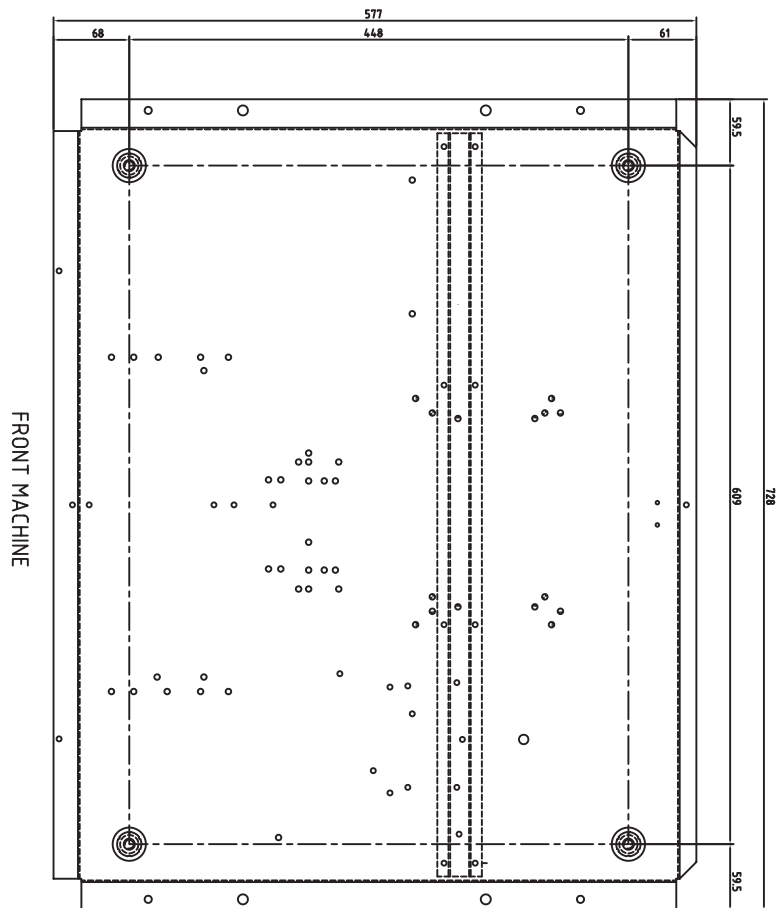
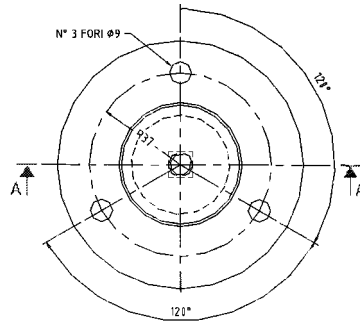
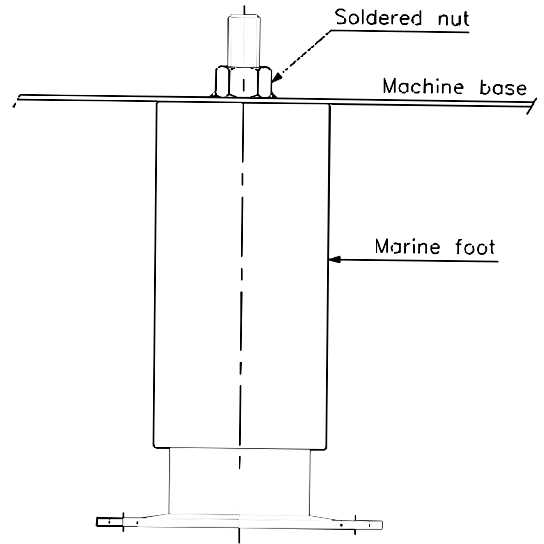

Marine foot

Technical specifications

Item	Model	Type	Specification
Production in 24h, till		184	21 kg
Production in 24h, till		249	24 kg
Production in 24h, till		316	33 kg
Production in 24h, till		425	46 kg
Production in 24h, till		640	65 kg
Production in 24h, till		955	90 kg
Production in 24h, till		1265	130 kg
Production in 24h, till		1565	155 kg
Production in 24h, till		42	42 kg
Storage capacity		184	4 kg, ~310 cubes
Storage capacity		249	9 kg, ~530 cubes
Storage capacity		316	16 kg, ~950 cubes
Storage capacity		425	25 kg, ~1470 cubes
Storage capacity		640	40 kg, ~ 2350 cubes
Storage capacity		955	55 kg, ~3240 cubes
Storage capacity		1265,1565	65 kg, ~3830 cubes
Storage capacity		42	12 kg, ~930 cubes
Condenser system			A,W
Kind of cube		249,316,425,640,955,1265,1565	A = 18g
Kind of cube		316,425,640,955,1265,1565	C = 33g
Kind of cube		184,249,316,425,640,955,1265,1565,42	D = 13g
Cold liquor			R404A
Standard voltage			220-240/1/52
Input power		184	320W
Input power		249	350W
Input power		316	400W
Input power		425	500W
Input power		640	650W
Input power		955	850W
Input power		1265	1050W
Input power		1565	1400W
Input power		42	450W
Water consumption	A	184	4,5 l/kg ice
Water consumption	A	249	5,1 l/kg ice
Water consumption	A	316	3,3 l/kg ice
Water consumption	A	425	6 l/kg ice
Water consumption	A	640	2,8 l/kg ice
Water consumption	A	955	2,5 l/kg ice
Water consumption	A	1265	2,8 l/kg ice
Water consumption	A	1565	2,6 l/kg ice
Water consumption	A	42	6 l/kg ice
Water consumption	W	184	37,4 l/kg ice
Water consumption	W	249	14 l/kg ice
Water consumption	W	316	13 l/kg ice

Technical specifications

Item	Model	Type	Specification
Water consumption	W	425	15 l/kg ice
Water consumption	W	640	12,8 l/kg ice
Water consumption	W	955	14,2 l/kg ice
Water consumption	W	1265	15,3 l/kg ice
Water consumption	W	1565	13 l/kg ice
Water consumption	W	42	15 l/kg ice
Feet		184,249	5 mm
Feet		42, 316,425,640,955,1265,1565	Adjustable
Size (WxDxH)		184	345x400x590 mm
Size (WxDxH)		249	390x460x690 mm
Size (WxDxH)		316	500x580x690 mm
Size (WxDxH)		425	500x580x800 mm
Size (WxDxH)		640	738x600x920 mm
Size (WxDxH)		955	738x600x1020 mm
Size (WxDxH)		1265,1565	840x740x1075 mm
Size (WxDxH)		42	500x630x920 mm
Size (with packing) (WxDxH)		184	410x470x660 mm
Size (with packing) (WxDxH)		249	430x500x790 mm
Size (with packing) (WxDxH)		316	540x620x790 mm
Size (with packing) (WxDxH)		425	540x620x900 mm
Size (with packing) (WxDxH)		640	780x640x1030 mm
Size (with packing) (WxDxH)		955	780x640x1130 mm
Size (with packing) (WxDxH)		1265,1565	880x784x1220 mm
Size (with packing) (WxDxH)		42	770x540x1040 mm
Weight net		184	28 kg
Weight net		249	37 kg
Weight net		316	48 kg
Weight net		425	56 kg
Weight net		640	77 kg
Weight net		955	89 kg
Weight net		1265	113 kg
Weight net		1565	118 kg
Weight net		42	66 kg
Weight gross		184	31 kg
Weight gross		249	44 kg
Weight gross		316	56 kg
Weight gross		425	64 kg
Weight gross		640	89 kg
Weight gross		955	102 kg
Weight gross		1265	133 kg
Weight gross		1565	138 kg
Weight gross		42	74 kg
Rerfrigerant R404A		184	140g
Rerfrigerant R404A		249	190g
Rerfrigerant R404A	A	316	260g
Rerfrigerant R404A	W	316	240g

Technical specifications

Item	Model	Type	Specification
Refrigerant R404A		42	240g
Refrigerant R404A	A	640	310g
Refrigerant R404A	W	640	240g
Refrigerant R404A	A	955	590g
Refrigerant R404A	A	955	510g
Refrigerant R404A	W	955	420g
Refrigerant R404A	A	1265	590g
Refrigerant R404A	W	1265	510g
Refrigerant R404A	A	1565	650g
Refrigerant R404A	W	1565	510g

A=AIR-CONDENSED, W=WATER-CONDENSED

184=CB184A, 249=CB249A, 316=CB316A, 425=CB425A, 640=CB640A, 955=CB955A, 1265=CB1265A, 1565=CB1565A, 42=DSS42

A=3/N/PE~400/230V 50Hz, B=~250V 16A 50Hz, H=3/PE~230V 50Hz, I=3/PE~220V 60Hz

DICHIARAZIONE CE DI CONFORMITÀ
EC DECLARATION OF COMPLIANCE
DECLARATION CE DE CONFORMITE
KONFORMITÄTSEKHLÄRUNG NACH EG-NORM
DECLARACION DE CONFORMIDAD A LA LEY CE
DECLARAÇÃO DE CONFORMIDADE DE COMUNIDADE EUROPEIA
EG-CONFORMITEITSVERKLARING
EF KONFORMITETSERKLÆRING
ΔΗΛΩΣΗ ΣΥΜΜΟΡΦΩΣΗΣ ΕΚ
FÖRSÄKRAN OM ÖVERENSSTÄMMELSE
CE KONFORMITETSERKLÆRING
CE YHDENMUKAISUSVAKUUTUS



BREMA Ice Makers S.p.A.

Via dell'Industria 10, 20020 Villa Cortese (MI)
Tel. +39+0331+434811 - Fax +39+0331+433833

PRODUTTORE DI GIACCIO A CUBETTI
Model CB 184A-Q
Construction N. 0174971/Serial N. 2002100174971

VILLA CORTESE
Milano - ITALIA
Luglio 2002

CESARE MAROU
Presidente
BREMA ICE MAKERS S.p.A.

CE The above-mentioned apparatus is designed for the production of ice. The undersigned declares under our own exclusive responsibility that the ice maker referred to in this declaration is in full compliance with the requirements of the following European Directives:

Machine 90/27/EEC and subsequent modifications. It complies with the essential requirements of safety and health as regards the design and manufacture of the machines, referred to in the following points of Attachment 1. Points 1.1.2), 1.1.3), 1.1.5), 1.2.3), 1.2.4), 1.3), 1.3.2), 1.3.4), 1.4.2), 1.5), 1.5.4), 1.5.10), 1.5.11), 1.6.1), 1.6.3), 1.6.5), 1.7.2), 1.7.4), 2.1), 4) b) of (6) (9) (b).

Low voltage 73/23/EEC and subsequent modifications.

Electromagnetic Compatibility 89/336/EEC and subsequent modifications.

Machinery and objects designed to come into contact with foodstuffs 86/109/EEC

Pressure equipment 97/23/EEC

It is in compliance with the following Harmonized Standards:

EN 292-1 Safety of machinery - basic terminology, nomenclature

EN 292-2 Safety of machinery - technical principles and specifications.

EN 294 Safety of machinery - safety distances to prevent danger zones being reached by the upper limbs.

EN 55014 Limits and methods of measurement of radio disturbance characteristics of electrical motor-operated and thermal appliances for household and similar purposes, electric tools and similar electrical apparatus.

EN 61000-3-2 Electromagnetic compatibility - Part 3: Limits - Section 2: Limits for harmonic current emissions (equipment with input current of 16 A per phase).

EN 61000-3-3 Electromagnetic compatibility - Part 3: Limits - Section 3: Limitation of voltage fluctuations and flicker in low-voltage supply systems for equipment with rated current of 16 A.

EN 60335-1 Safety of household and similar electrical appliances. General requirements.

EN 60335-2-24 Safety of household and similar electrical appliances - Part 2: Particular requirements for refrigerators and food freezers.

EN 378 parts: 1 - 2 - 3 - 4 refrigeration systems and heating pumps - Safety and environmental requirements.

EN 12786 parts: 1 - 2 - 3 - 4 refrigeration systems and heating pumps - Safety and environmental requirements.

Ministerial Decree of March 21, 1973 and subsequent updates. Regulations covering hygiene of packaging, recipients, tools and equipment, designed to come into contact with foodstuffs and substances for personal use.

5 Överensstämde maskin är avsedd för tillagning av is. Undertecknade bekräftar härmed på eget och fullt ansvar att den maskin som åryktas i denna Förklaring sålvida överensstämmer med kornen i följande EU-direktiv:

"Maskin" 90/27/EMG och senare ändringar. Den uttrycker de väsentliga krav på säkerhet och hälsa vid utformning och tillagning av maskiner som åryktas under följande punkter i Bilaga 1: 1.1.3), 1.1.5), 1.1.5.1), 1.2.3), 1.2.4), 1.3.1), 1.3.2), 1.3.4), 1.4.2), 1.5), 1.5.1), 1.5.4), 1.5.10), 1.5.11), 1.6.1), 1.6.3), 1.6.5), 1.7.2), 1.7.4), 2.1) a) b) d) (9) b).

"Lågspänning" 73/23/EMG och senare ändringar.

"Tryckutrustning" 97/23/EMG och senare ändringar.

Maskiner och produkter avsedda att komma i kontakt med livsmedel" 86/109/EMG.

"Tryckutrustning" 97/23/EMG.

Överensstämmer med följande harmoniserade standarder:

EN 292-1 - Säkerhet för maskintillagning. Grundläggande begrepp, allmänna konstruktionsprinciper. Terminologi, benämning.

EN 292-2 - Säkerhet för maskintillagning. Grundläggande begrepp, allmänna konstruktionsprinciper. Specifikationer och tekniska principer.

EN 294 - Säkerhetsavstånd - Skyddsavstånd som berör att man når säkerhetszonen med händer och armar.

EN 55014-1 - Radiostörningar - Radiostörningar från elektriska hushållsapparater, elverktyg och liknande apparater - Gränsvärden och mätmetoder.

EN 61000-3-2 - Elektromagnetisk kompatibilitet (EMC) - Del 3: Gränsvärden - Gränsvärden för harmoniska strömskälade strömmar med nominellström högst 16 A per fas.

EN 61000-3-3 - Elektromagnetisk kompatibilitet (EMC) - Del 3: Gränsvärden - Begränsning av spänningsfluktuationer och harmoniska strömskälade strömmar för utrustning med nominellström högst 16 A.

EN 60335-1 - Elektriska hushållsapparater och liknande utrustning - Säkerhet - Del 1: Allmänna förordningar.

EN 60335-2-24 - Elektriska hushållsapparater och liknande utrustning - Säkerhet - Del 2: Särskilda förordningar på kylar och frysar för hushållsbruk på bänkskåp.

EN 378 delar: 1, 2, 3 och 4 - Kylsystem. Värmepumpar - säkerhets- och miljökrav.

Överensstämmer med följande tekniska specifikationer:

Ministeriärende 21/3/73 och senare ändringar. Hygienbestämmelser för förpackningar, behållare, verktyg och utrustning avsedda att komma i kontakt med livsmedel.