

Viking Combi 200 litres

Safe and reliable combi kettle for cooking and mixing

ELECTRIC MG4224210



metos
cooking solutions

Metos Cooking Solutions

Ahjonkaarre, FI-04220 Kerava, Finland

Tel. +358 204 3913

mcs@metos.com

mcs.metos.com



Standard features kettle with mixer

- Kettle with integrated mixer
- Stepless mixing speed 15-120 rpm, autoreverse
- Two mixing programs
- Elevated control pillar with selected features
- Tilting height 600 mm
- Hydraulic tilting
- Safety grid lid
- Measuring stick

Wide range of accessories available.

Options

- Frames for fixed installation (custom heights on request)
- Free standing kettles with feet
- Cooking bowl cover plates welded and seamless with closed cell polyurethane foam insulation
- Alternative operating voltages
- Food temperature display
- Automatic measured food water filling
- Manual or automatic cooling with tap water
- Steam jacket automatic fill
- Connection to external HACCP system
- Hand showers, Standard, Reel-in or Heavy Duty
- Draw off valves and taps

Materials

- Construction stainless steel (EN1.4301, EN1.4404)
- Inner surface acid proof stainless steel
- Protection class IPX5

Volumes

Viking Combi	Brut L	Net L	Spare volume L
200	219	200	19

Heat load

Viking Combi	Total kW	Sensible kW	Latent kW
200	33.6	6.1	1.4

Viking Combi 200 litres

A. Electrical connections from rear

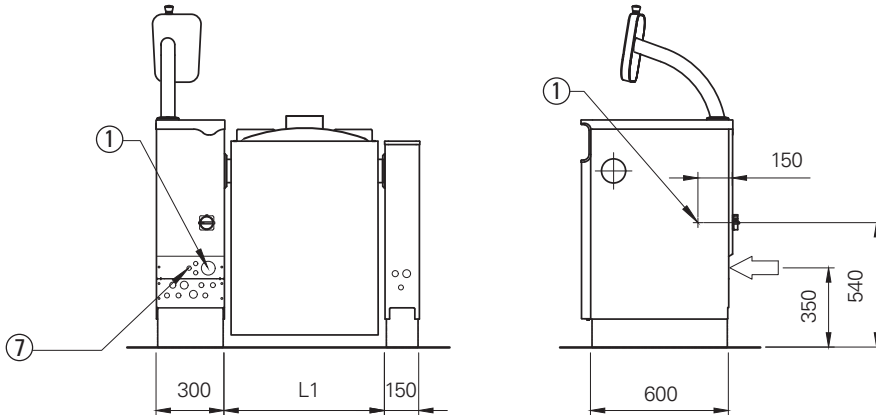

- 1. Electrical connection, PG21/PG36/PG48 gland
- 7. HACCP cabling (option)

B. Electrical connections from below

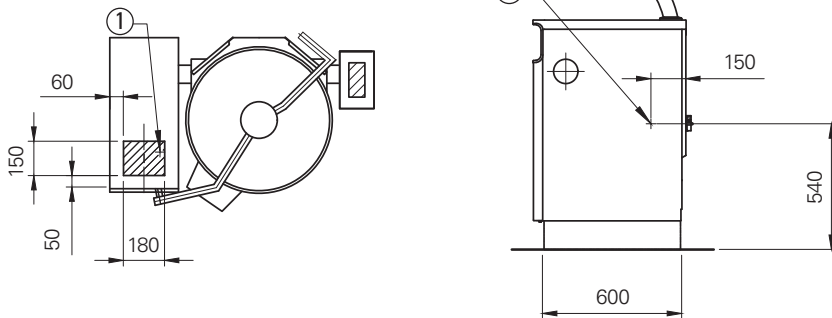

A. Water and steam connections from rear

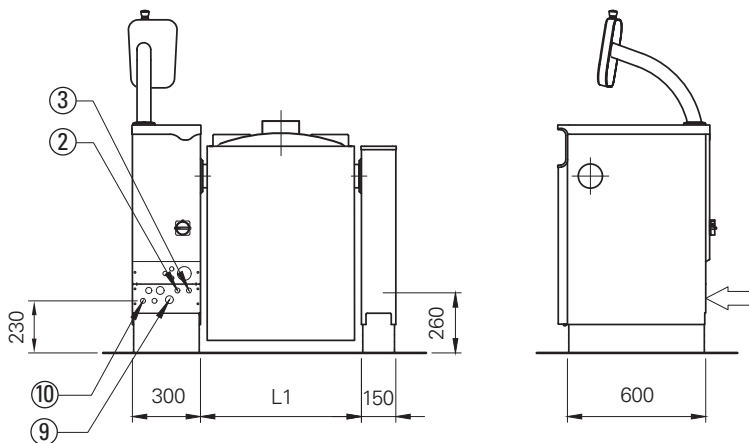

- 2. Cold water connection R1/2" (ø15), to be fitted with non-return valve and shut off valve
- 3. Hot water connection R1/2" (ø15), to be fitted with non-return valve and shut off valve (option)
- 9. Steam connection R3/4" / R1" / R1 1/4" (option)
- 10. Condensate outlet R1/2" / R3/4" (option)

B. Water and steam connections from below

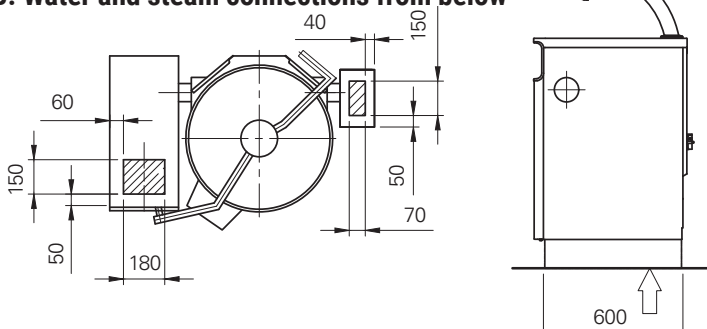

Viking Combi 200 litres

Electrical connections, ELECTRIC heated kettles

Viking Combi	Connected power/kW	Current A	Fuse 3xA
200E	33.6	59	63

3/N/PE AC 400/230V 50/60Hz

Group installation connections

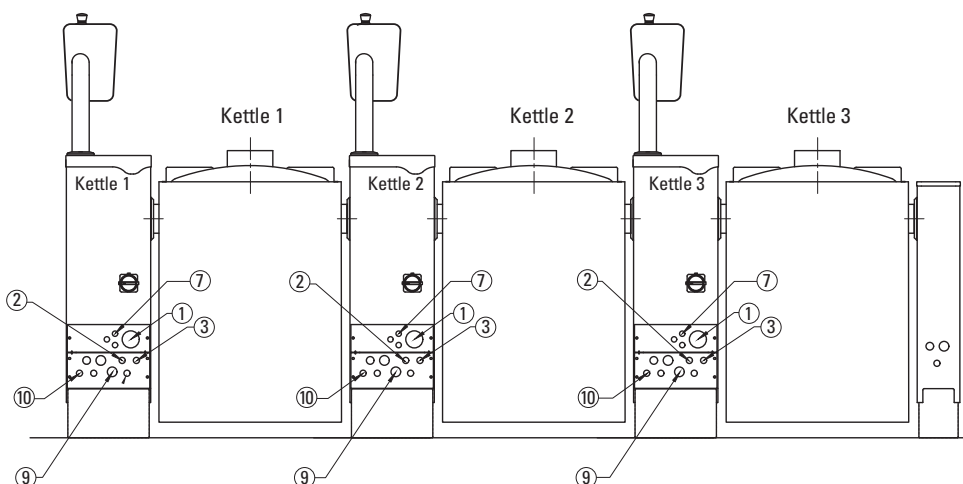

- 1. Electrical connection, PG21/PG36/PG48 gland
- 2. Cold water connection R1/2" (ø15), to be fitted with one way valve and shut off valve
- 3. Hot water connection R1/2" (ø15), to be fitted with one way valve and shut off valve (option)
- 7. HACCP cabling (option)
- 9. Steam connection R3/4" / R1" / R1 1/4" (option)
- 10. Condensate outlet R1/2" / R3/4" (option)

Viking Combi 200 litres

Dimensions

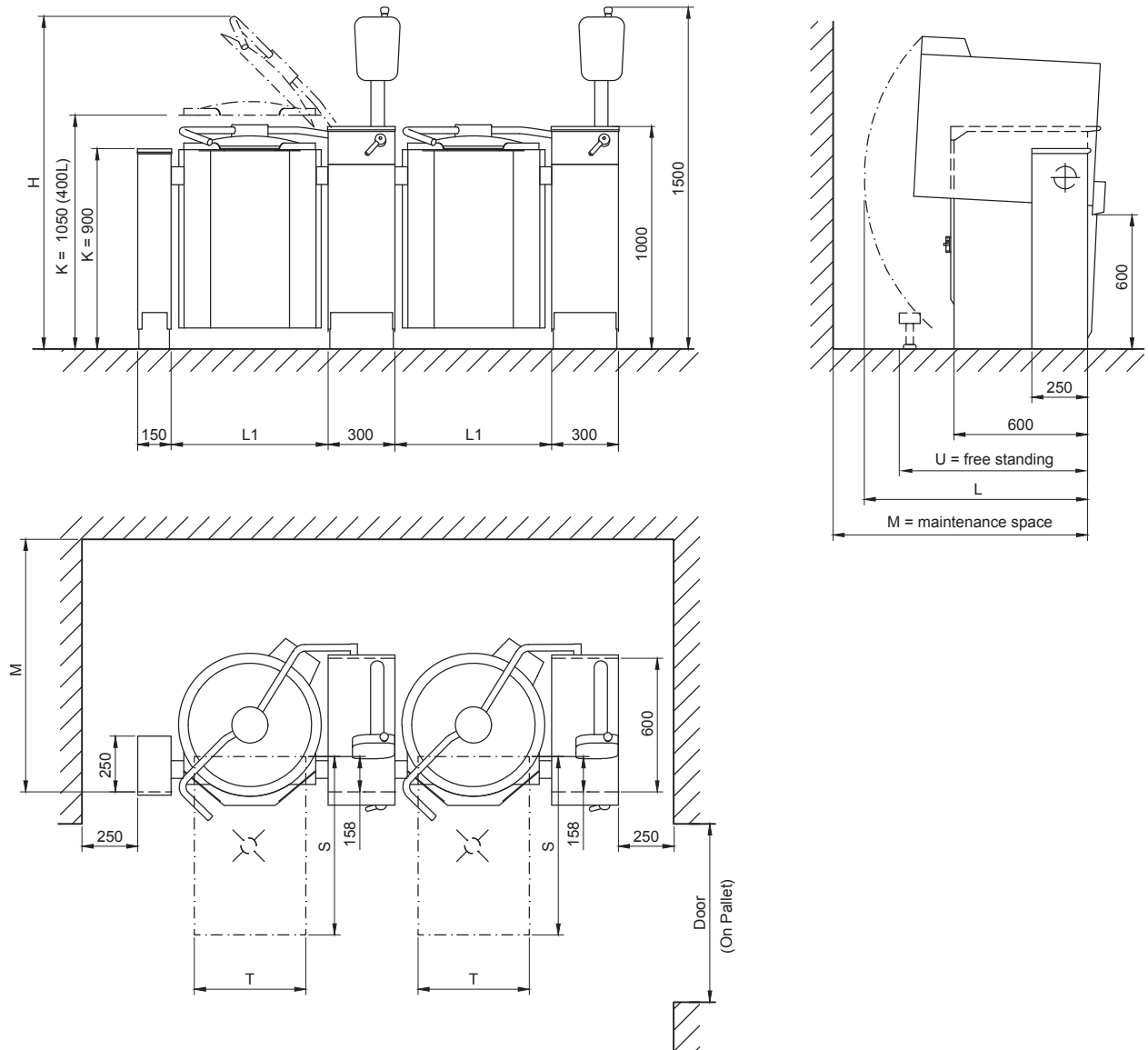

Viking	L1 (mm)	H (mm)	K (mm)	L (mm)	M (mm)	S (mm)	T (mm)	U (mm)	Door (mm)	(On Pallet) Size varies according to installation frame	Viking Combi (kg)
200	910	1945	900	1195	1285	800	600	1110	1000	(1100-1300)	340

National and local regulations must be observed when installing the kettle.

an Ali Group Company



The Spirit of Excellence