

**metos**  
kitchen intelligence<sup>®</sup>

## **Metos Classic** **Hygienic all stainless steel kitchen units**



# CLASSIC ASSORTMENT

- 30 mm front edge profile and 30 x 30 mm leg tubing
- Three standard depths of tables 650, 700 or 800mm
- Lengths up to 5000 mm
- All stainless steel stand construction
- Wide range of sinks
- Efficient soundproofing
- Sink accessories for different purposes
- Adjustable legs  $\pm 20$  mm
- Stand cupboards and drawers also with castors
- Splashback standard height 60 - 200 mm
- Tabletop thickness 1,0 mm - 1,2 mm
- Ergonomy
- Hygiene
- Modular stand elements 400 mm

Also the underside of the table can be washed with water, because the whole frame is stainless steel.

Wide range of sinks, base elements, wall elements and accessories: cover plates, tabletops of wood, stone or plastic etc.



## CONSTRUCTION

Frame and legs 30x30 mm stainless steel tubing. Tabletop 1,0 mm - 1,2 mm stainless steel plate with 30 mm edge profile. Tabletop is supported with stainless steel tubes. Noise insulation between frame and tabletop. Number of legs depends on table length and purpose of use. Material: stainless steel 18/10 1.4301.

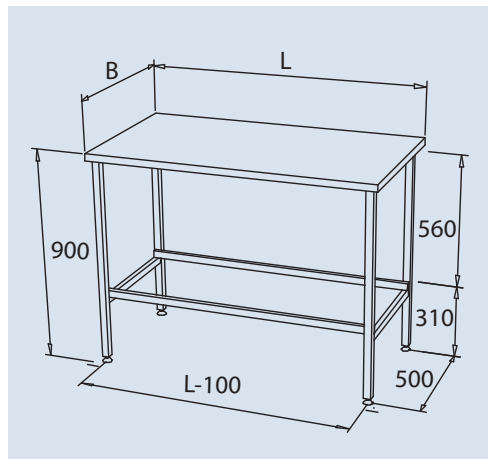

## PROFILES

Standard profiles are presented in the drawings. Also special profiles and special splashbacks are available.



### WASH TABLE

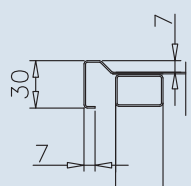

A. Wash table front profile

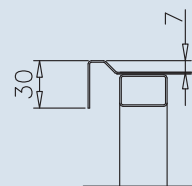

B. Wash table side and rear profiles

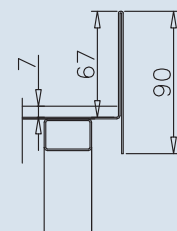

C. Wash table rear profile with splashback

### WORK TABLE

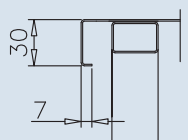

D. Work table front profile

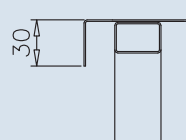

E. Work table side and rear profiles

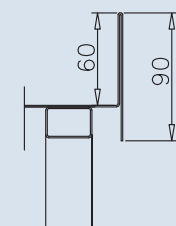

F. Work table rear profile with splashback

# ALL STAINLESS STEEL BASE ELEMENTS

## CUPBOARDS

The body is of single casing construction. Double casing construction with noise insulation in doors. Doors strengthened with deep drawn pattern. Chromed handles, stainless steel hinges and door magnet. Stainless steel shelves, adjustment interval 25 mm.

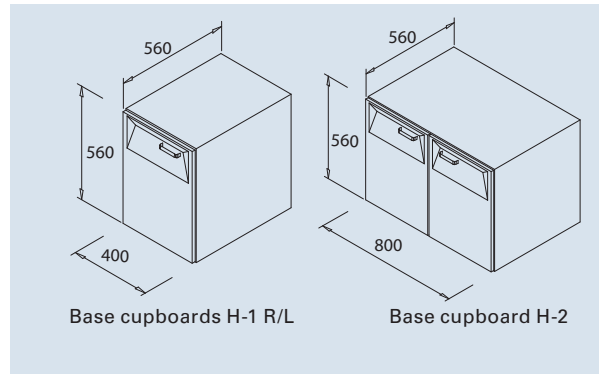

## DRAWERS

### DRAWERS WITH PLASTIC RUNNERS

The body is of single casing construction. Front panels strengthened with deep drawn pattern. Chromed handles. Plastic runners, GN containers included.

### DRAWERS WITH TELESCOPIC RUNNERS

The body is of single casing construction. Front panels strengthened with deep drawn pattern. Chromed handles. Galvanised telescopic runners without GN containers. Drawers can be pulled out entirely.

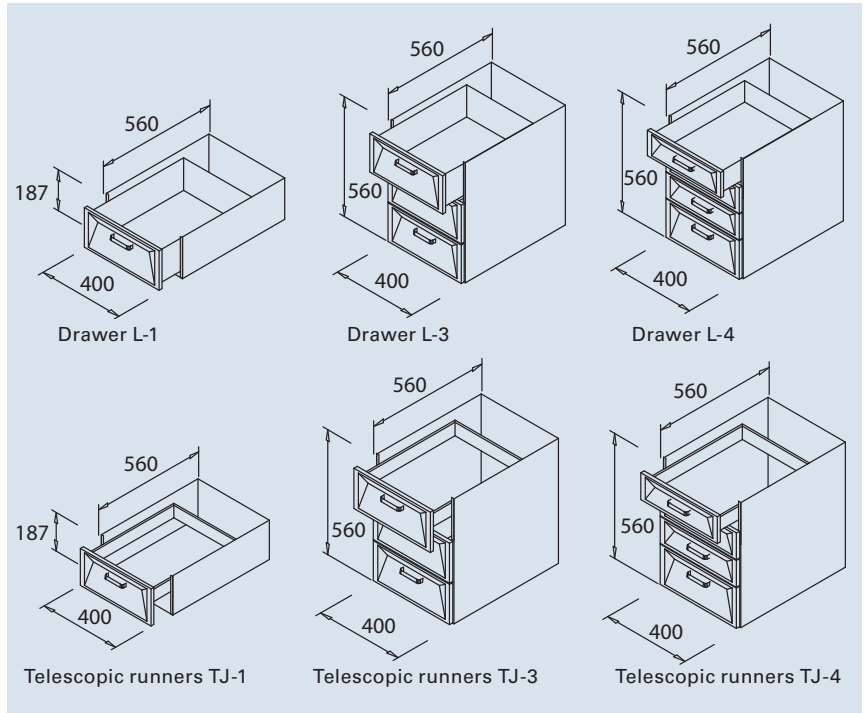

## OTHER BASE ELEMENTS

Shelf elements are of dishwasher safe stainless steel.

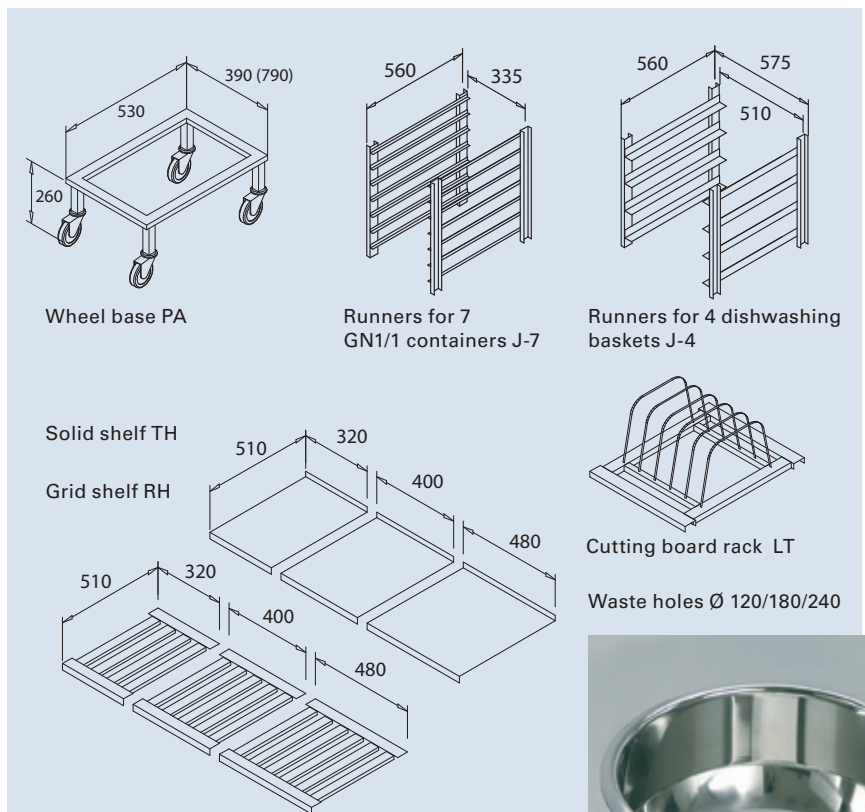



# WALL SHELVES

## STAINLESS STEEL SHELVES

Shelves stainless steel with 25 mm profile and 25 mm rear edge heightening. Depths 300, 400 or 500 mm. Solid and grid shelves available.

## WALL RAILS AND SHELF BRACKETS

Wall rails and shelf brackets are of anodised aluminium. Stepless height adjustment. Hygienic construction. Quick and easy to install. Wall rail distance normally 800-1000 mm. Shelves can be used also above island work tables by welding the upright bars to the table frame.



Straight and slanted shelf bracket

### Shelf brackets

041 straight	200 mm
041 straight	300 mm
041 straight	400 mm
041 straight	500 mm
051 straight	500 mm
051 slanted	500 mm

### Wall rails (with screw holes)

300 mm
600 mm
900 mm
1200 mm
1600 mm
2000 mm

### Shelf standard lengths

580 mm
680 mm
780 mm
880 mm
980 mm
1080 mm
1180 mm
1280 mm
1380 mm
1480 mm
1580 mm
1680 mm
1780 mm
1880 mm
1980 mm

# FLOOR AND WALL CUPBOARD



The body is of single casing construction. Double casing construction with noise insulation in doors. Chromed handles, stainless steel hinges and door magnet. Stainless steel shelves, adjustment interval 25 mm. Floor cupboard with 4 shelves. Sock height of floor cabinet 150 mm. Single door cupboards can be ordered right or left handed.

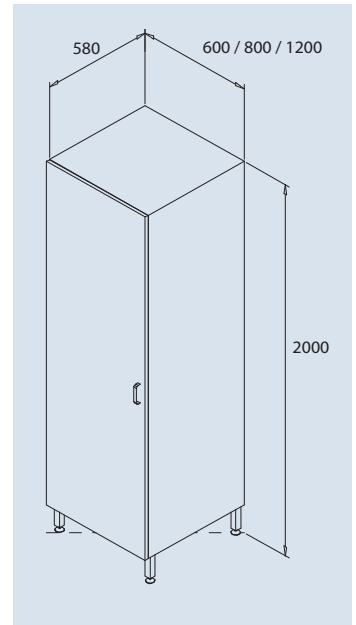
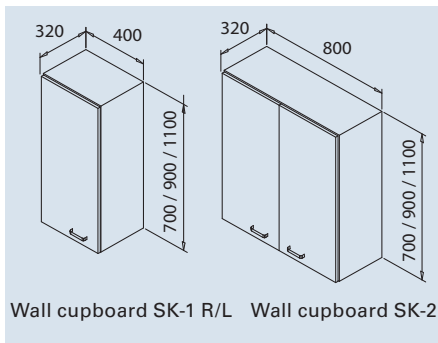

Floor cupboard, width 600 R/L, 800, 1200 mm



## Metos Manufacturing

Ahjonkaarre

FI-04220 Kerava, Finland

Tel +358 204 3913

international.sales@metos.com

www.metos.com/manufacturing

